

**Brickcom**

Megapixel Cube Network Camera

**CB-100A series**

User's Manual

Quality Service Group

Product name: Network Camera (CB-100A series)

Release Date: 2010/8

Manual Revision: V1.4

Web site: [www.brickcom.com](http://www.brickcom.com)

Email: [technical@brickcom.com](mailto:technical@brickcom.com)

[info@brickcom.com](mailto:info@brickcom.com)

©2010 Brickcom Corporation. All Rights Reserved

## Table of Contents

Before You Use This Product .....	0
FCC Warning .....	0
Regulatory Information.....	0
Package Contents.....	0
Cube Network Camera Overview.....	1
Device Appearance Description .....	3
LED Behavior.....	4
Installation.....	6
System Requirements .....	6
Camera Connection .....	7
Basic Connection.....	7
Software Installation .....	8
Accessing the Network Camera.....	24
Check Network Settings .....	24
Add Password to Prevent Unauthorized Access .....	24
Authentication.....	25
Installing the Plug-In .....	26
Live View.....	27
Configuration.....	30
Camera/Video/Audio .....	30
Camera.....	30
Video.....	32
Audio.....	35
Multicast.....	36
Privacy Mask Control.....	37
Network .....	38
IP Settings .....	38
UPnP .....	39
DDNS (dynamic domain name service).....	40
EasyLink™ .....	41
Wireless.....	42
HTTP/HTTPS.....	49
Event .....	51
Event Settings.....	51
Motion Detection.....	55
PIR(*).....	56

Audio Detection .....	57
Notifications.....	58
FTP Settings .....	58
E-mail Settings.....	59
Samba Settings .....	60
HTTP Settings .....	61
Video Clip .....	62
Audio Clip(*).....	63
LED Light(*) .....	64
System .....	65
System Log.....	65
Date and Time .....	67
Device Information.....	68
Storage Management(*).....	69
LED Indicators .....	70
Maintenance.....	71
User Management .....	71
Language.....	72
IP Filter .....	72
Firmware Upgrade .....	73
Configuration .....	73
Reset to Default .....	74
Reboot .....	74



## Before You Use This Product

In many countries, there are laws prohibiting or restricting the use of surveillance devices. This Network Camera is a high-performance, web-ready camera which can be part of a flexible surveillance system. It is the user's responsibility to ensure that the operation of this camera is legal before installing this unit for its intended use.

Upon opening the product's package, verify that all the accessories listed on the "Package Contents" are included. Before installing the Network Camera, read the warnings in the "Quick Installation Guide" to avoid misuse. When installing the Network Camera, carefully read and follow the instructions in the "Installation" chapters to avoid damages due to faulty assembly or installation.

## FCC Warning

This device complies with Part 15 of FCC rules.

Operation is subject to the following two conditions;

- (1) This device may not cause harmful interference, and
- (2) This device must accept any interference received, including interference that may cause undesired operations.

## Regulatory Information

### Federal Communication Commission Interference Statement

This equipment has been tested and found to comply with the limits for a Class B digital device, pursuant to Part 15 of the FCC Rules. These limits are designed to provide reasonable protection against harmful interference in a residential installation. This equipment generates uses and can radiate radio frequency energy and, if not installed and used in accordance with the instructions, may cause harmful interference to radio communications. However, there is no guarantee that interference will not occur in a particular installation. If this equipment does cause harmful interference to radio or television reception, which can be determined by turning the equipment off and on, the user is encouraged to try to correct the interference by one of the following measures:

- Reorient or relocate the receiving antenna.
- Increase the separation between the equipment and receiver.
- Connect the equipment into an outlet on a circuit different from that to which the receiver is connected.
- Consult the dealer or an experienced radio/TV technician for help.

FCC Caution: Any changes or modifications not expressly approved by the party responsible for compliance could void the user's authority to operate this equipment.

This device complies with Part 15 of the FCC Rules. Operation is subject to the following two conditions: (1) This device may not cause harmful interference, and (2) this device must accept any interference received, including interference that may cause undesired operation.



#### **IMPORTANT NOTE:**

#### **FCC Radiation Exposure Statement:**





This equipment complies with FCC radiation exposure limits set forth for an uncontrolled environment. This equipment should be installed and operated with minimum distance 20cm between the radiator & your body.

This transmitter must not be co-located or operating in conjunction with any other antenna or transmitter.

The availability of some specific channels and/or operational frequency bands are country dependent and are firmware programmed at the factory to match the intended destination. The firmware setting is not accessible by the end user.

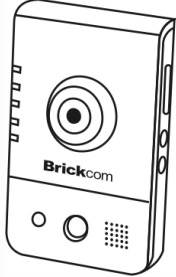
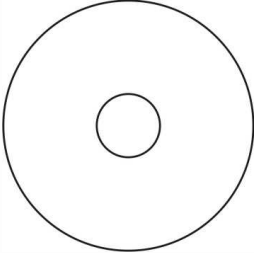
## Package Contents

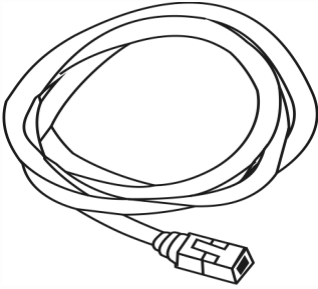
Please check to make sure the product package contains all the accessories listed below.

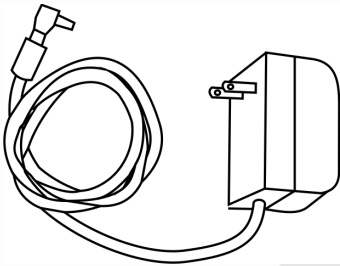
<p>a. CB-100A/ WCB-100A</p> 	<p>b. Product CD</p> 
<p>c. Camera Stand</p> 	<p>d. White Flat RJ-45 cable(1.5m)</p> 
<p>e. Warranty Card</p> 	<p>f. Power Adapter</p> 

## Cube Network Camera Overview

The compact Brickcom CB-100A Cube network series offers a high quality, video surveillance solution for residences and small businesses. Unlike a general webcam, this camera series is a standalone surveillance system that does not need to be connected to a computer. EasyLink™ is a feature of the CB-100A camera which allows for users to simply plug in the camera to any home or small business network and play the video.

This camera series offers a user-friendly and unique design which allows anyone without a technical background to use it. It features live video feed and two-way audio which can be used over a local area network (LAN), through any internet browser, or via any 3G mobile device. The wireless capability makes it easy to mount on any surface. The CB-100A features many cutting edge functions and its fashionable, streamline design make it the perfect additional for any home or office.

Because of its many advanced features, the CB-100A has many versatile applications. Users can easily monitor the safety of their family members, pets, office, valuables, and property.



### **Small Office Surveillance –**

Security systems for small offices can be expensive and difficult to install and maintain. With the EasyConfig software, the CB-100A can easily be installed and configured by anyone without extensive technical knowledge. The video can be reviewed remotely so business owners can monitor office safety and employee productivity at all times.





## Residence monitor –

Home owners worry about their house and property when they are away. The CB-100A has a built-in PIR sensor which can detect unauthorized movement in a residence. Once movement is detected, the illumination LED will be triggered and an alert with a snapshot can be emailed or sent through an MMS to the user's portable device.



## Elderly and Child Care –

A high concern for many people is the safety of elderly relatives and small children. Users can use the CB-100A camera to ensure the safety of their loved ones by use of the live view and intercom functions.



## Pet Monitor –

The motion detection feature can be used to create forbidden areas in the home which the pet should not enter when the owner is away. If the camera records the pet entering the region, a recorded message can be programmed to play and the owner will be notified via email or MMS.

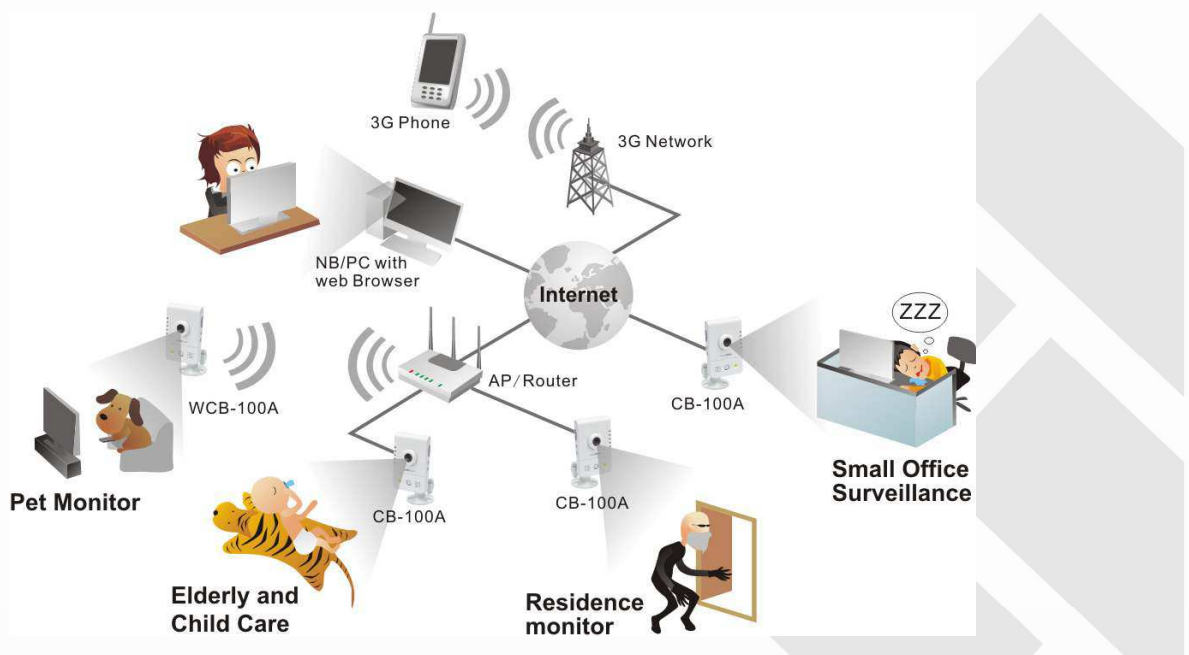

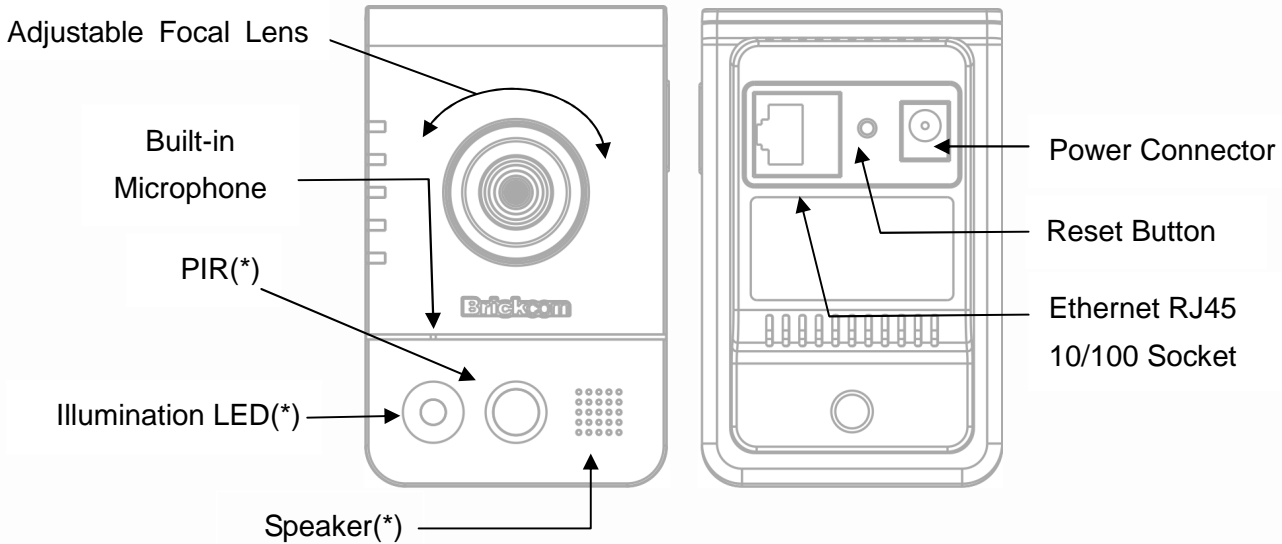

## Device Appearance Description

< Front & Rear view >

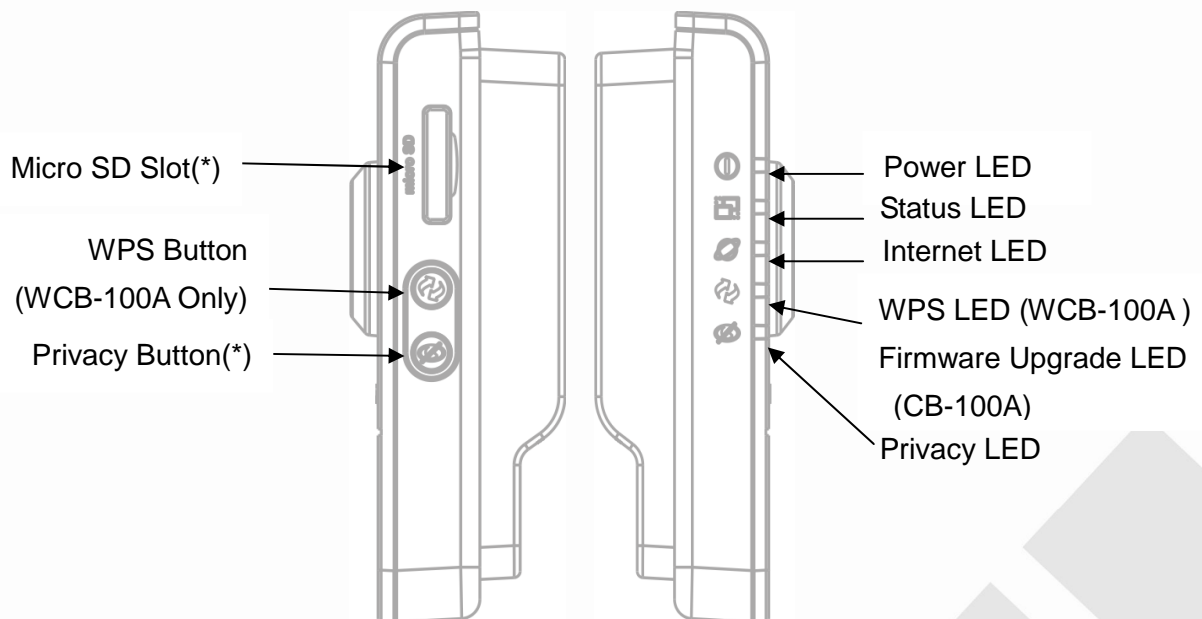

<Side view>



1.  NOTE - The WPS and Privacy buttons must first be enabled through the web GUI in order to work. See page 37 for details on how to enable the Privacy button and see page 50 for details on how to enable the WPS Button.
2. (\*) These are optional features. Please refer to the Product List for the full list of optional features available for the product.

## LED Behavior

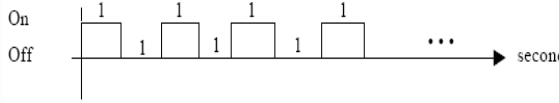
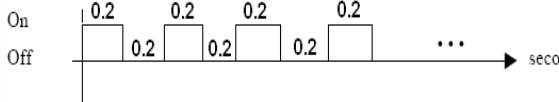
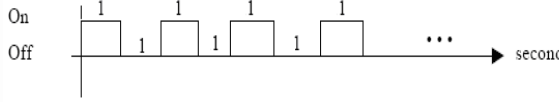
Function	LED Behavior	Description	Remark
Power	Continuous Illumination	Normal Operation	Top (Blue)
Power	Unlit	Powered off	Top (Blue)
Status	Continuous Illumination	1. Connected to switch by Ethernet or WiFi. 2. Reset to default.	Second (Blue)
Status	Unlit	1. Powered off 2. No connection	Second (Blue)
Status		1. Upgrading F/W 2. Performing site survey	Second (Blue)
Status	Blinking	1. .Connecting to the network 2. Restoring settings.	Second (Blue)
Internet	Continuous Illumination	Connected to Internet	Third (Blue)
Internet	Unlit	1. Powered off 2. No connection	Third (Blue)
WPS		WPS in progress	WCB-100A Fourth (Blue)
WPS		WPS Connection Error	WCB-100A Fourth (Blue)

<b>WPS</b>		Session overlap detected	WCB-100A Fourth (Blue)
<b>WPS</b>	<b>Continuous Illumination</b>	WPS success	WCB-100A Fourth (Blue)
<b>Firmware Upgrade</b>	<b>Continuous Illumination</b>	Firmware successfully upgraded	CB-100A Fourth (Blue)
<b>Privacy</b>	<b>Continuous Illumination</b>	Privacy mask active	Bottom(Red)
<b>Privacy</b>	<b>Unlit</b>	Privacy mask inactive	Bottom(Red)

## Hardware Reset

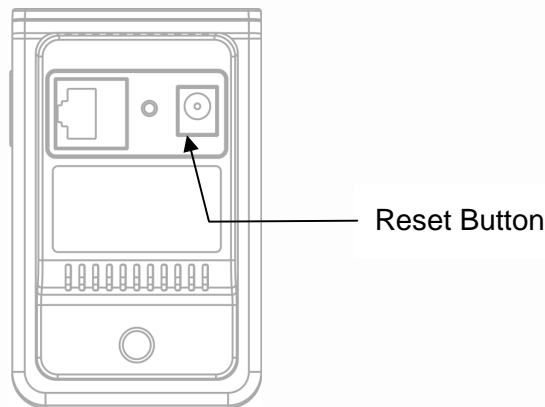

The Reset Button can be used to reboot the camera or restore it to factory default settings. If the camera experiences a problem, rebooting the camera may correct the problem. If the problem remains, please restore the camera to factory default settings and reinstall the software.

**To Reboot** - Press and hold the Reset Button for one second using a paper clip or thin object.

Wait for the camera to reboot.

**To Restore** – Press and hold the Reset Button for ten seconds until the LED light turns off.

When successful restored, the LED will be blue during normal operation.



**NOTE** - By restoring the camera, all settings will be restored to the factory default settings.

## Micro-SD/SDHC Card Capacity

The network camera is compatible with Micro-SD/SDHC (Maximum 32GB) cards.

## Installation

### System Requirements

#### Operating System:

Microsoft Windows XP Home Edition SP2

Microsoft Windows XP Professional SP2

#### Computer:

IBM PC/AT Compatible

#### CPU:

Pentium 3GHz or faster

#### Memory:

1024 MB or more

#### Monitor:

1024 x 768 pixels or more, 24-bit True color or better

#### Network Interface:

10/100Mbps Network interface card must be installed

#### Web Browser:

Microsoft Internet Explorer 6.0 SP2 or higher

#### Adobe Reader:

Adobe Reader 8.0 or higher

#### Audio:

The audio function will not work if a sound card is not installed in the PC. Audio may be interrupted depending on network traffic.

## Camera Connection

### Basic Connection

1. Connect the supplied power cable from the camera to a power outlet.
2. Connect the camera to a switch using an Ethernet cable.

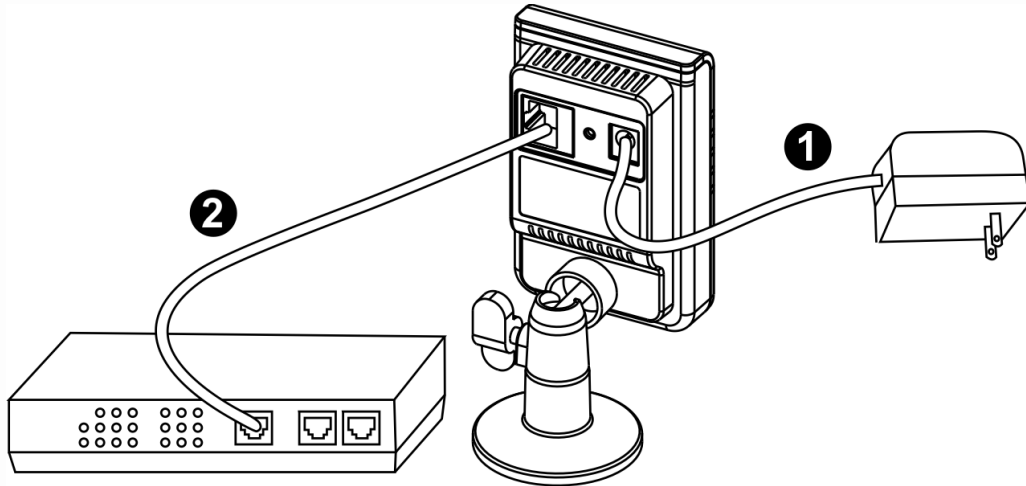

When powering up, the power LED will light up and the camera will boot up. The status LED will turn amber when the camera is obtaining the IP address. After obtaining the IP address, the link LED will flash orange while the network connection is processing.

## Software Installation

In this manual, "User" refers to whoever has access to the Network Camera, and "Administrator" refers to the person who can configure the camera and grant user access to the camera.

After checking the hardware connection, run the Installation Wizard program included on the product's CDROM to automatically search the intranet for the camera. There may be many cameras on the local network. Differentiate the cameras using the serial number which is printed on the labels on the carton and the bottom of the camera.

1. Insert the Installation CD into the CD-ROM driver. Run Auto-Run Tool directly from the CD-ROM to start the installation. When installing the Brickcom software kit for the first time, select a desired language for the interface. The available languages are listed in the scroll box. Click **<Install>** and follow the steps to install the EasyConfig wizard on the desired computer.



2. In the Install Shield Wizard dialog box, click <Next> to continue.

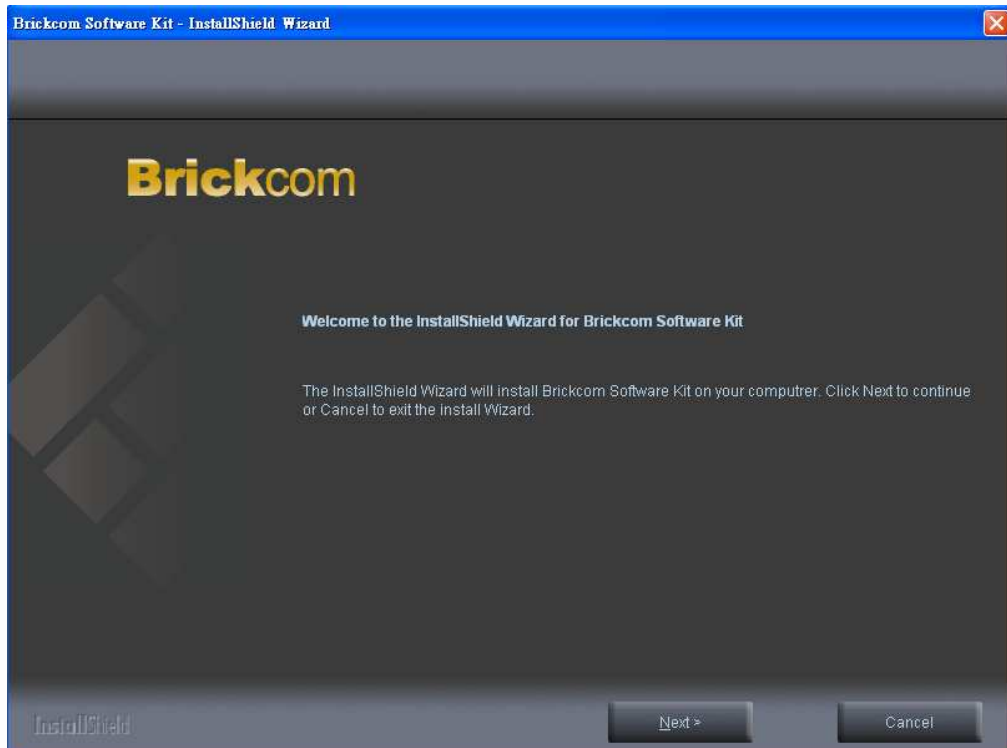

3. Read the End-User License Agreement and check the option "I accept the terms of the license agreement". Click <Next> to continue.

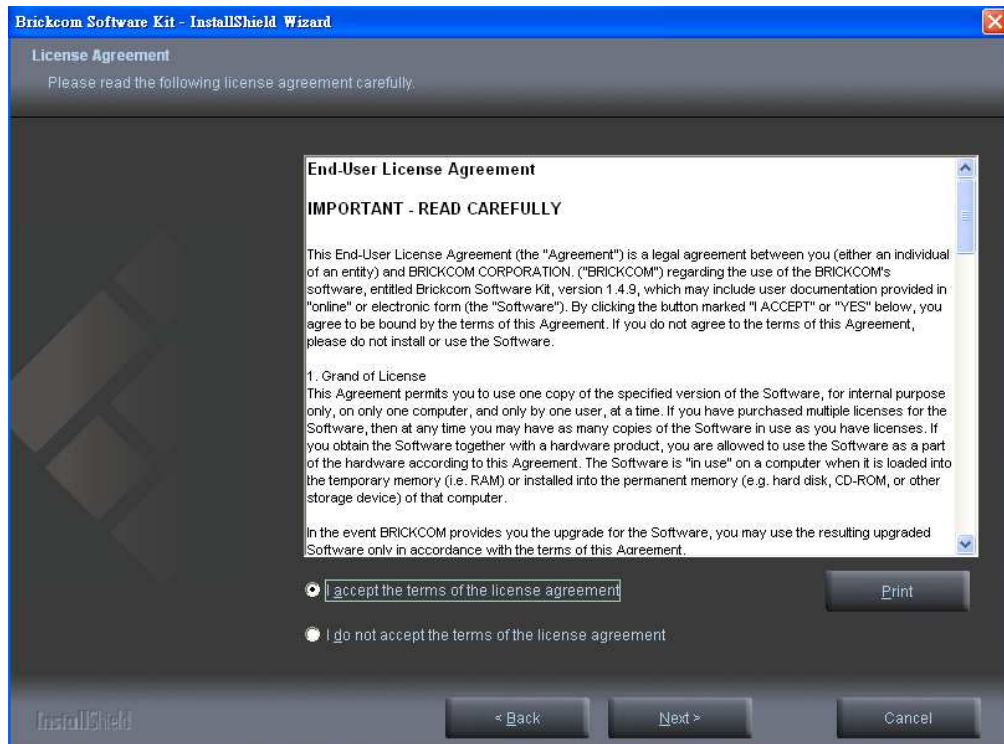



4. Select either “Complete” setup or “Custom” setup to install the system.

a. If **COMPLETE SETUP** is selected:

i. **All program features** will be installed into the default directory. Check the option “**Complete**” and then click <Next>.

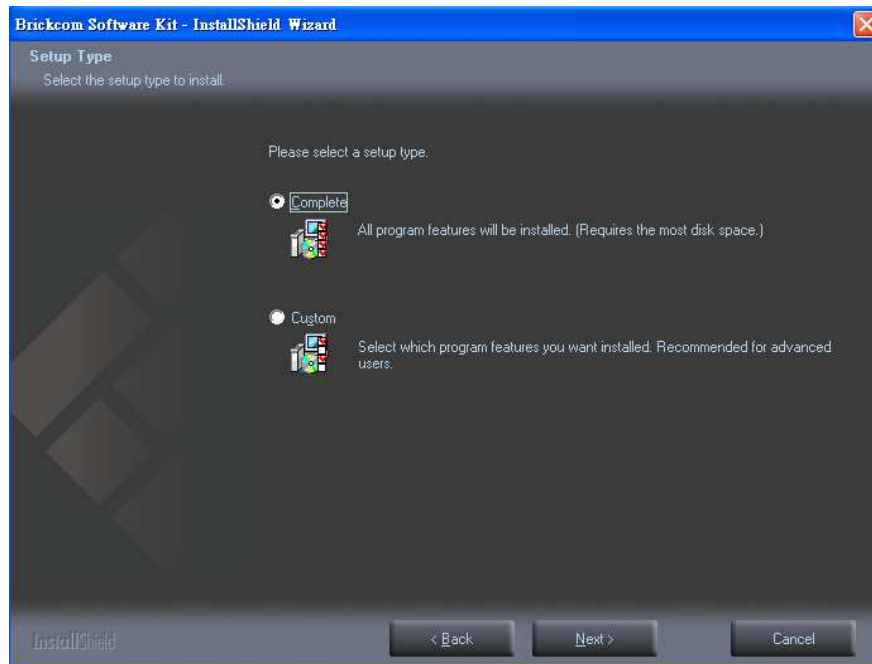

ii. Select to create shortcuts. Click <Next> to continue.

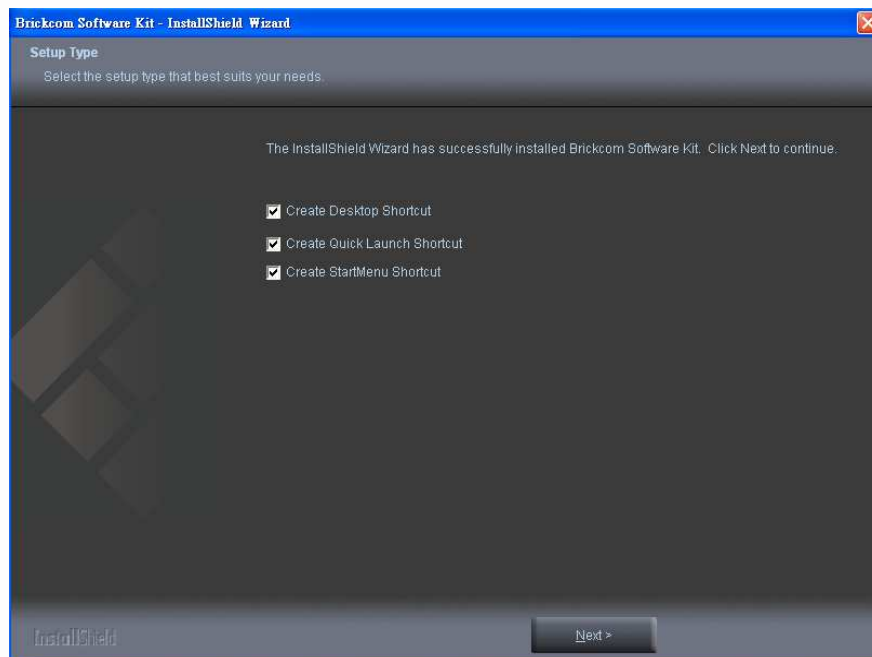

- iii. The installation information will be displayed. Click <Next> to continue.

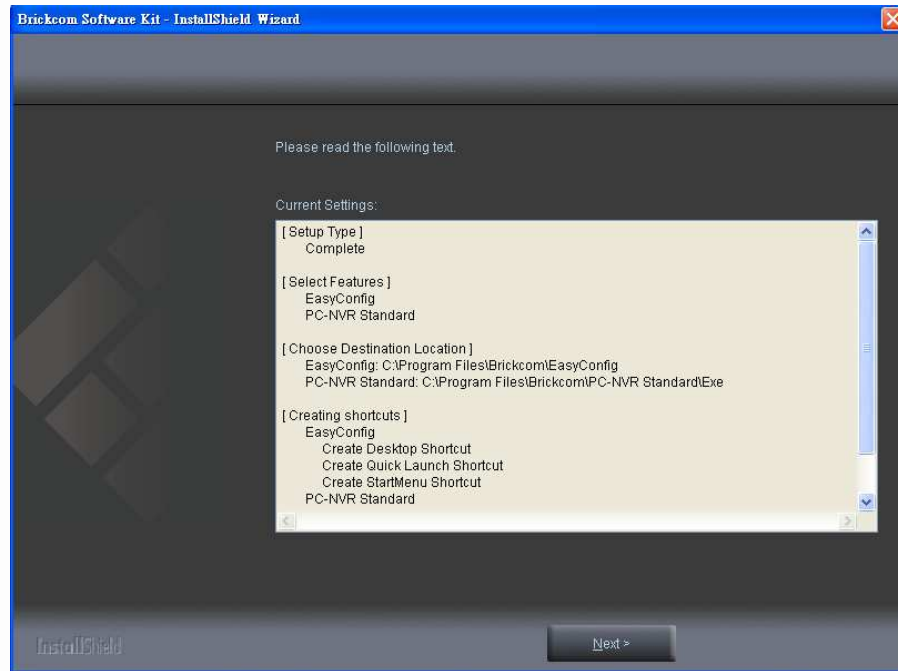

b. **If CUSTOM SETUP is selected:**

- i. This option is recommended for advanced users. It can be used to install the system to a preferred directory or to select specific program feature(s).
- ii. Check the option “**Custom**”, and then click <Next>.

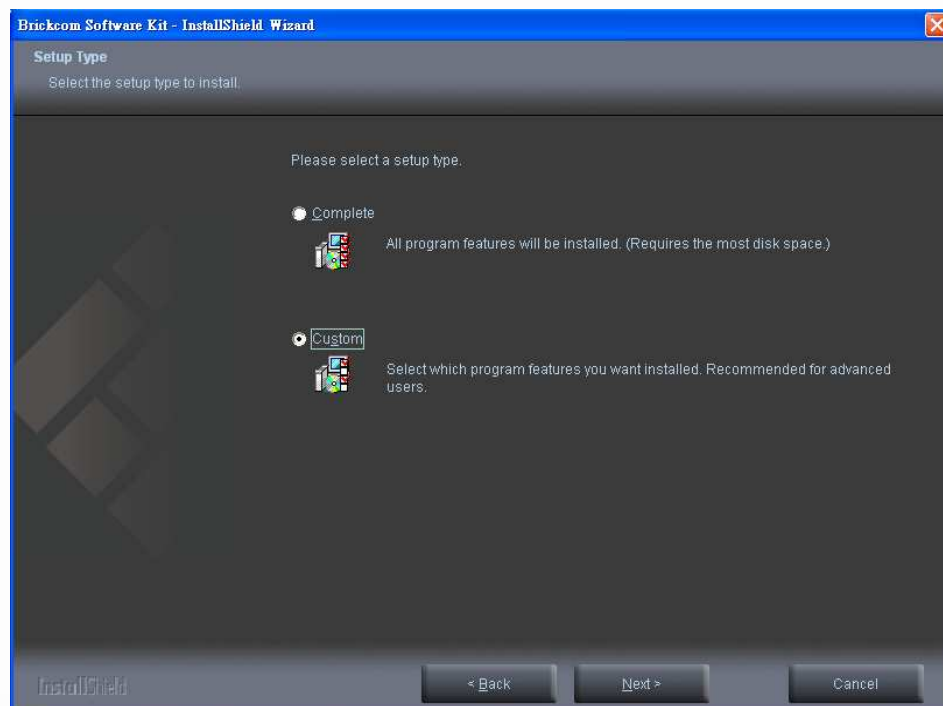

iii. Select the features to install. Click <Next> to continue.

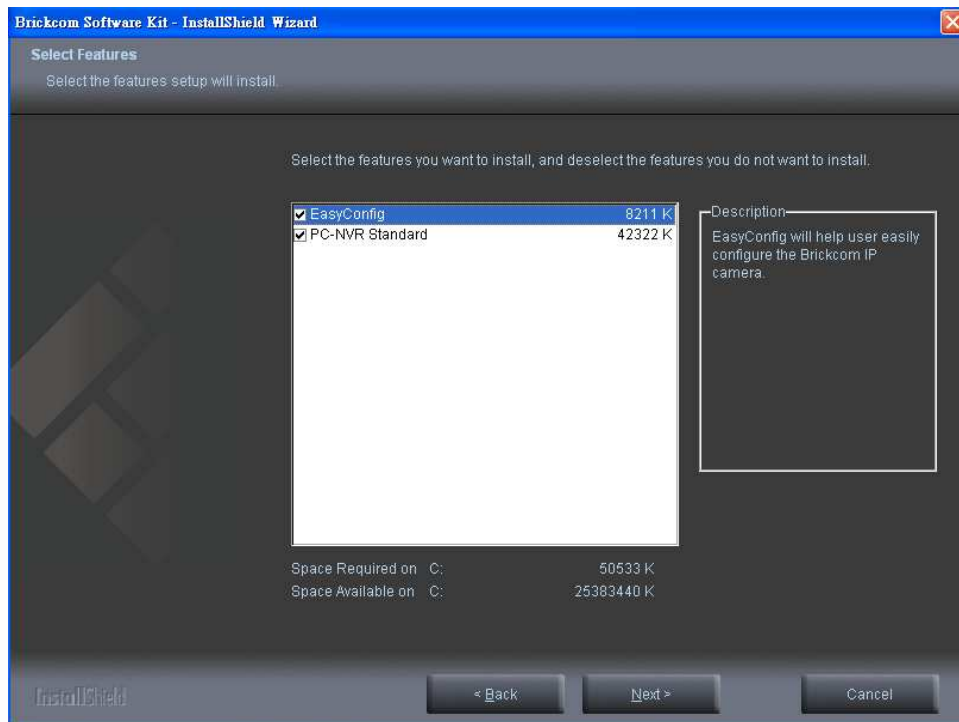

iv. Click <Change> to change the appointed folder where installation and program files will be stored. Click <Next> to continue.

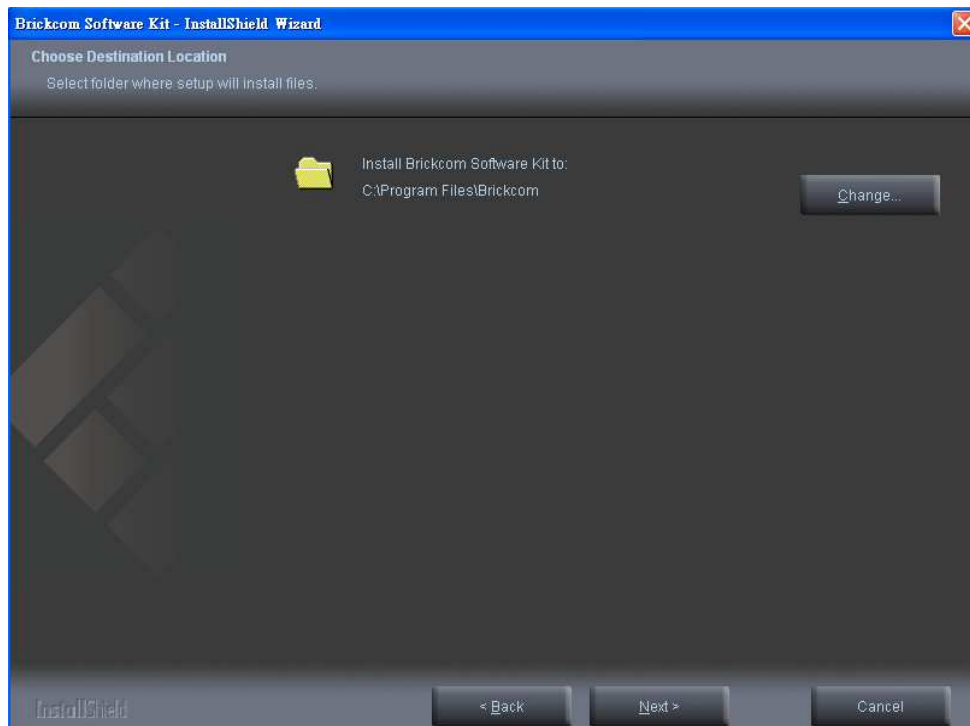

- v. Select programs to create shortcuts. Click <Next> to continue.

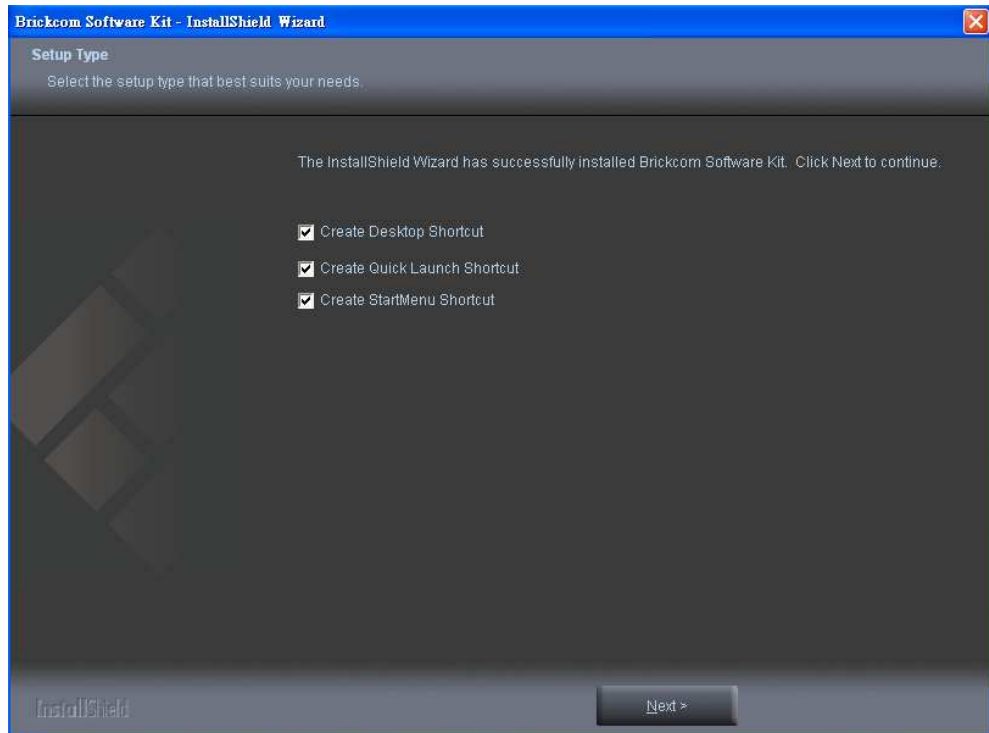

- vi. The installation information will be displayed. Click <Next> to continue.

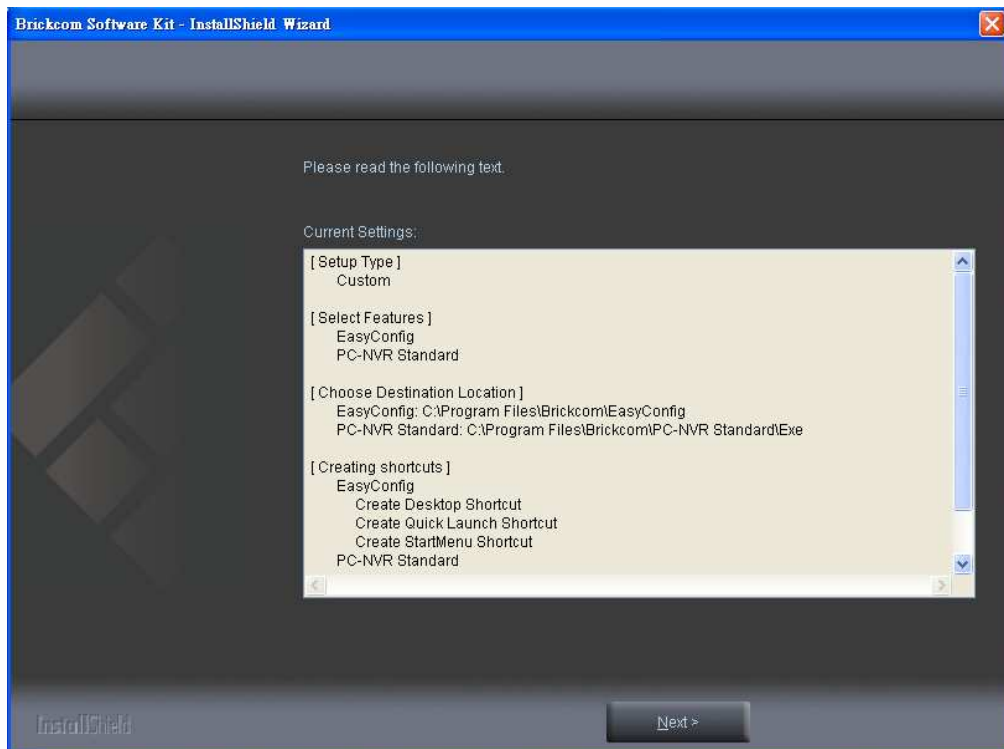

5. To launch EasyConfig or PC-NVR Standard, select the application and click <Finish>.

When launching the PC-NVR program, please refer to the PC-NVR user manual.

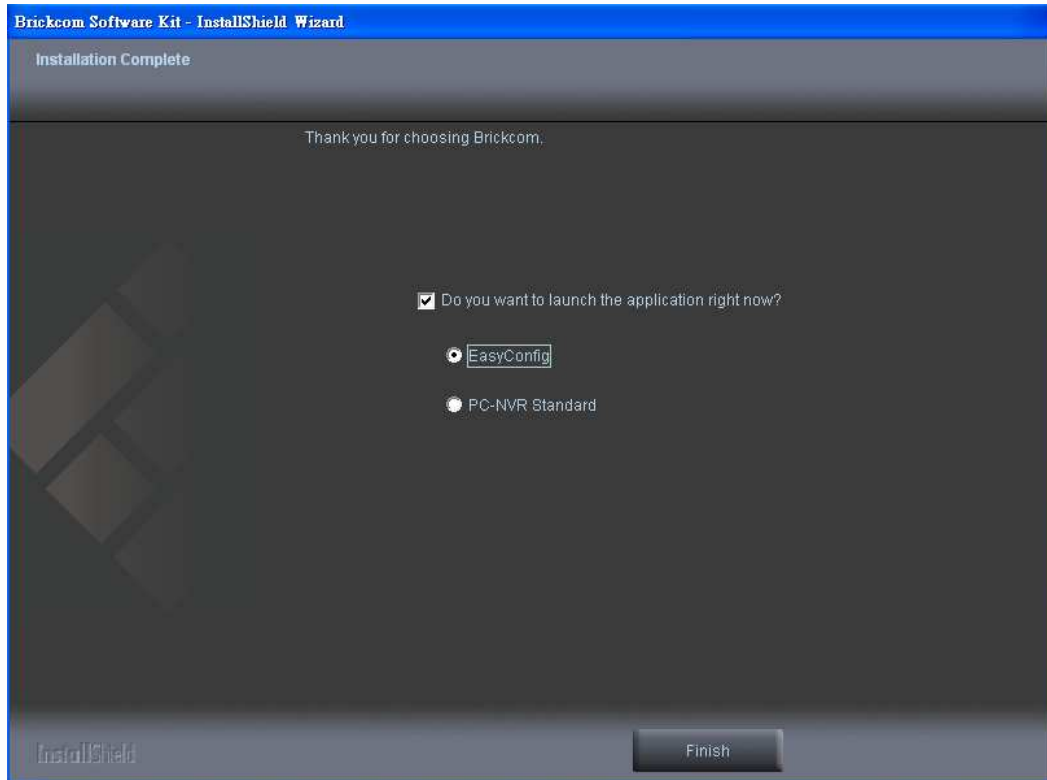

## EasyConfig

To launch EasyConfig, select EasyConfig from the start menu. If Complete Setup type was used in the software installation, an EasyConfig icon was installed on the desktop. Double click to open the icon.

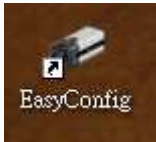

If Custom Setup type was used in the software installation and an EasyConfig icon was not installed on the desktop, the program will be installed under C:\Program Files\Brickcom\EasyConfig unless the program was saved to a preferred directory.

1. Click <Start> to continue. The program will automatically search for the camera in the intranet.



**NOTE** - Check “Skip the hardware installation guide” to skip checking the hardware connection. To check the hardware installation settings, do not check the option box.



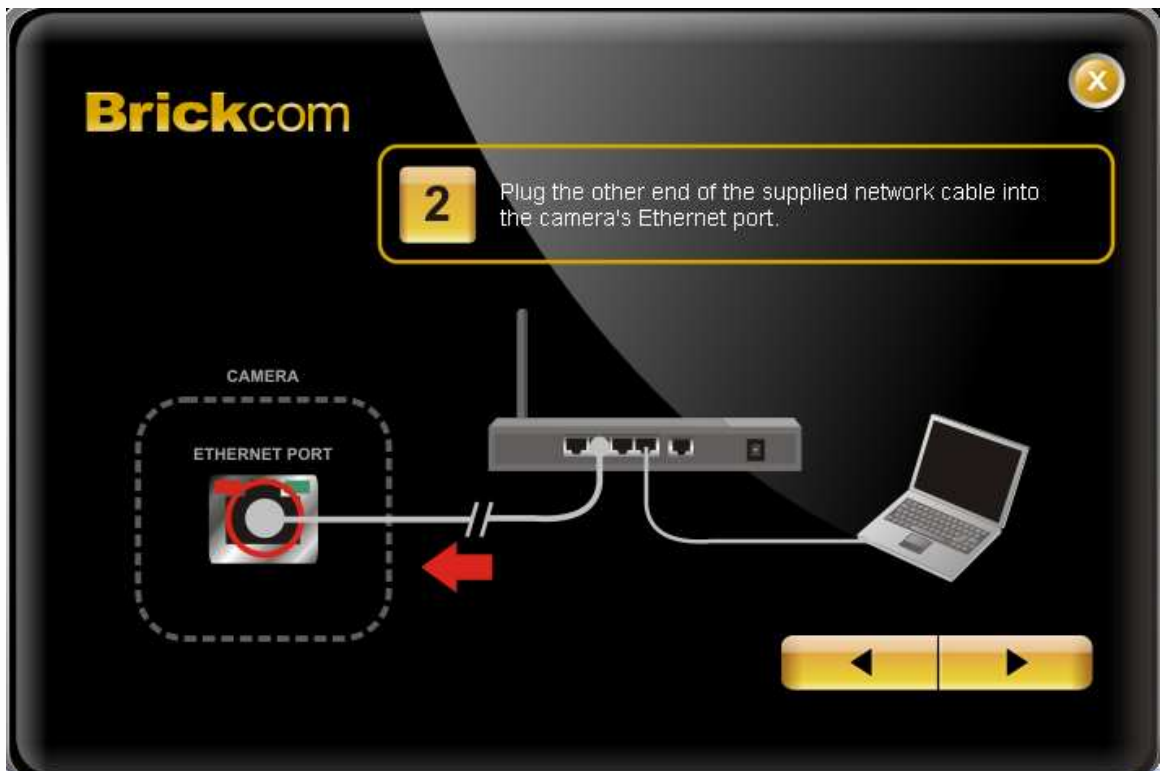
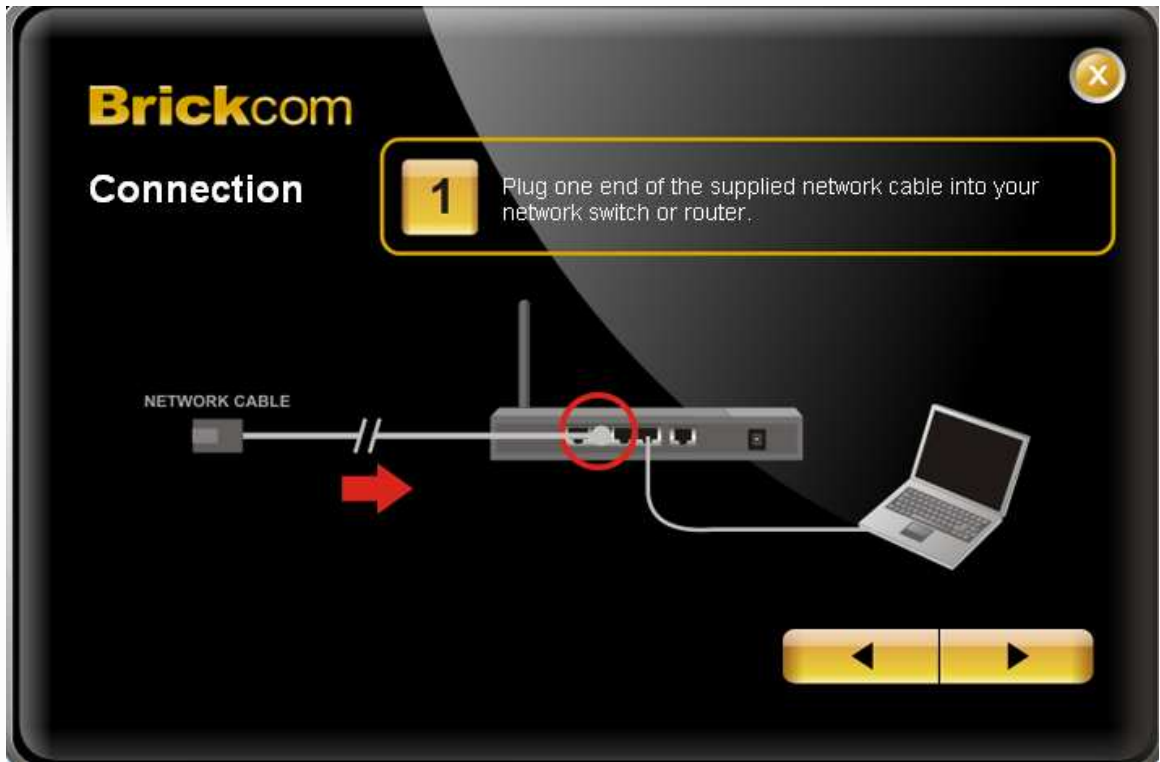

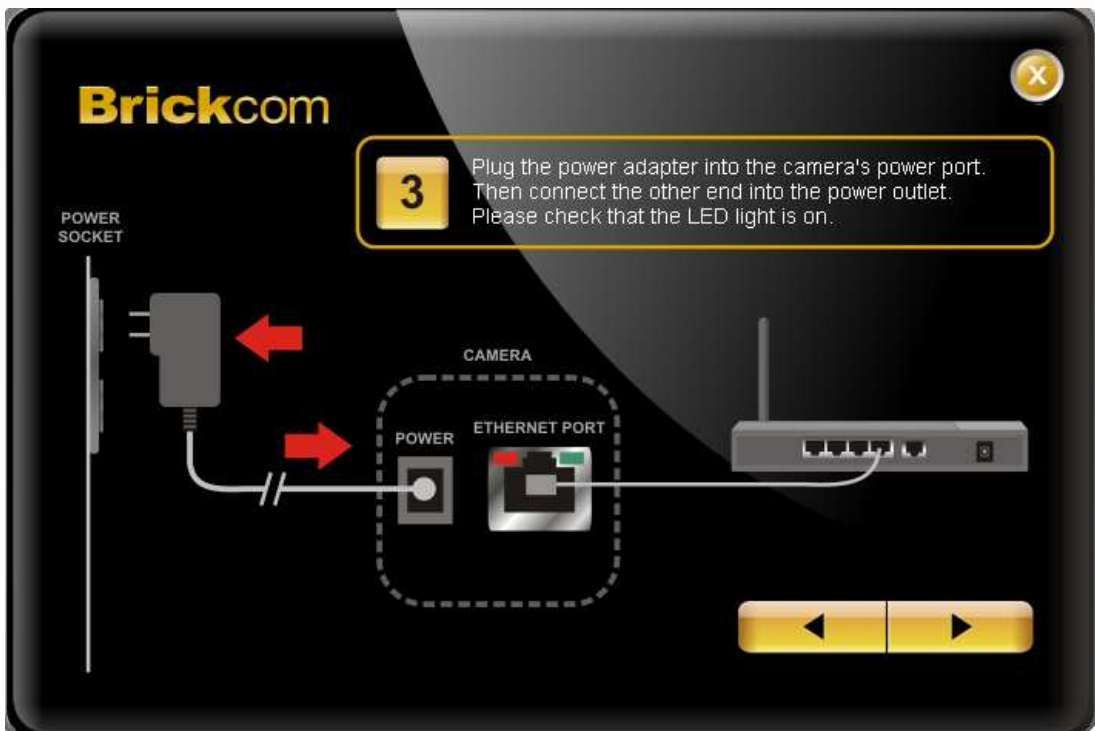

2. Select either "Simple Mode" or "Professional Mode" to obtain the camera's IP settings. If "Simple Mode" is selected, EasyConfig will set up the connection automatically. If "Professional Mode" is selected, the user will need to configure the IP settings manually.





3. There may be many cameras in the local network. Differentiate the cameras using their UPnP name. Double click on the camera from the survey list to connect.

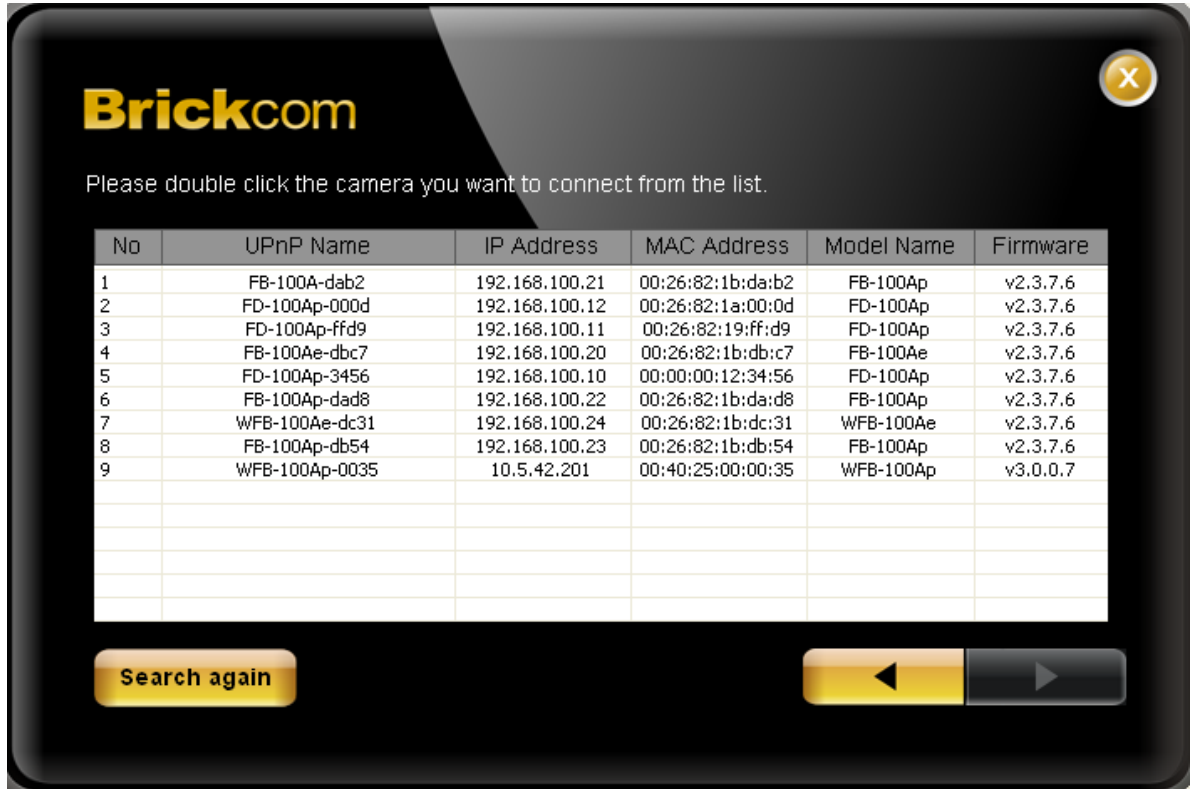

4. Enter the username and password of the camera. For first time use, the default username and password are "admin/admin."



5. For configuring the IP address settings, select either <Settings remain the same>, <Automatically obtain an IP Address (DHCP)> or <Set IP Address configuration manually>. The DHCP setting is recommended.



- a. If <Set IP Address configuration manually> is selected, the following pages will be displayed.



**Brickcom**

Enter the Static IP Address to configure IP Camera.

IP Address

Subnet Mask

Gateway

DNS1

DNS2



6. If the camera supports the EasyLink™ function, the following page will be displayed. Otherwise, this page will not be shown. \*If desired, click <Skip> to skip this setting.



EasyLink™ is a unique Brickcom function which allows users to assign a unique domain name to their network camera's IP address. There is no need to configure the router to open up ports or remember hard-to-memorize IP addresses. When this feature is enabled, users can log onto [uniquedomainname].mybrickcom.com to view the camera's web GUI and live view.

1. Check the option box to enable EasyLink™. Enter a domain name whose length must be between 5-32 characters.
2. For Refresh Time, select a desired amount of time from the drop-down menu to confirm the connection status.
3. When finished, click the arrow button to continue.
4.  **NOTE** - See page 41 for more details about the EasyLink function.

7. When the IP address settings have been configured, the screen will either display a successful or failed connection message. If the connection failed, either try again or quit the installation.

a. If “DHCP IP address settings” was selected, the failure page will be displayed as below:

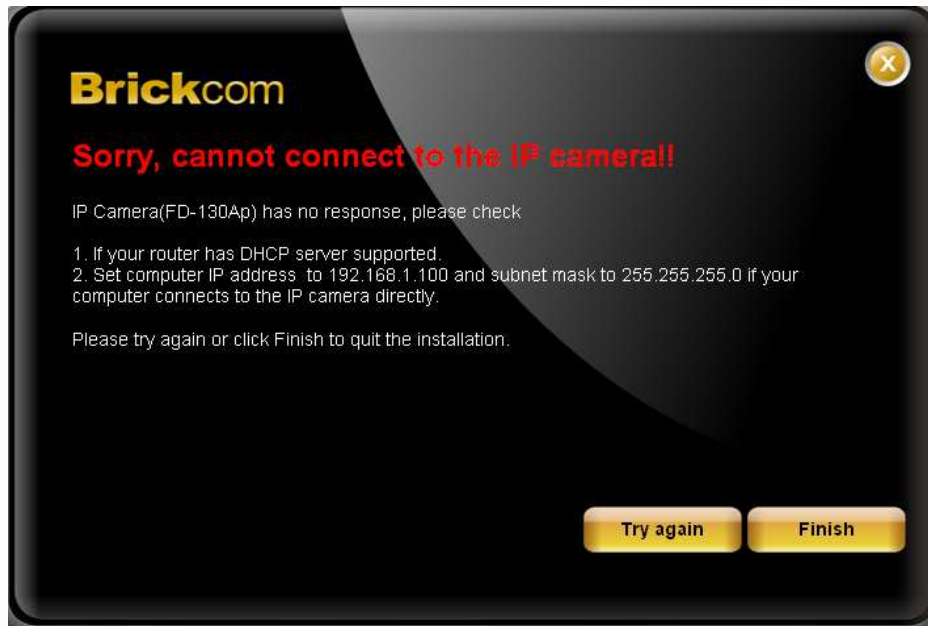

b. If “Static IP address settings” was selected, the failure page will be displayed as below:

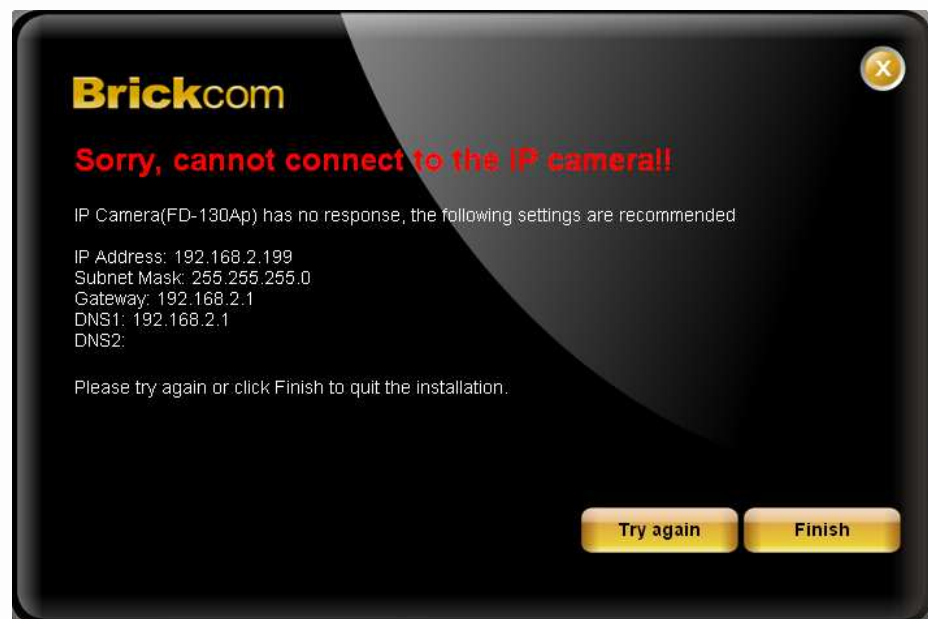

- c. If the connection was successful, the user will see the message:  
“Congratulations. The installation of the camera is complete.”

When this window is displayed, click **<PC-NVR>** to start the PC-NVR program, **<Live View>** to view the live video from the connected IP camera, or **<X>** in the top right corner of the screen to close the installation window. To run the PC-NVR program, please refer to the PC-NVR user manual for more information.



Once installation is complete, the Administrator should proceed to the next section "Accessing the Network Camera" for necessary changes and configurations.

## Accessing the Network Camera

### Check Network Settings

The camera can be connected either before or immediately after the software installation. The Administrator should complete the network settings on the configuration page, including entering the correct subnet mask and IP address of gateway and DNS. Ask the network administrator or Internet service provider for the detail information.

### Add Password to Prevent Unauthorized Access

**The Administrator should immediately implement a new password as a matter of prudent security practice. For first time use, the user name and password for the Administrator are assigned as “admin/admin”. After the Administrator changes the Administrator password, the web browser will display an authentication window to confirm the new password. Once the password is set, there is no provision to recover the Administrator’s password. If the Administrator’s password is lost, the only option is to restore the original factory default settings.**

The Administrator can set up a maximum of ten (10) user accounts. Users will be able to access the Network Camera, but will not be allowed to access system configurations.

The Administrator can set up a maximum of ten (10) user accounts. Users will be able to access the Network Camera, but will not be allowed to access system configurations.

## Authentication

To access the camera's live view, open a web browser and enter the IP address of the camera. A dialog window will pop requesting a username and password. As stated on the previous page, for the default username and password for the Administrator are assigned as "**admin/admin**". For accounts other than the administrator's account, the user can choose to remember the password for future convenience. It is not recommended to check this box when viewing the camera feed from a public computer.





## Installing the Plug-In

For the initial access to the camera in Windows, the web browser may prompt the administrator for permission to install a new plug-in for on Internet Explorer. Permission request depends on the Internet security settings of the user's PC or notebook. If the highest security level is set, the computer may prohibit any installation and execution attempt. This plug-in has been registered for certificate and is used to display the video in the browser.

Click on  to proceed. If the web browser does not allow the administrator to continue the installation, check the Internet security option and lower the security levels or contact the networking supervisor or IT for help.



 **NOTE** – If an error occurred or the plug-in fails to install, it is because the version of the Electronic Signature is newly released and the VeriSign has not been submitted to Microsoft Windows update for validation. Therefore, plug-in will not have its root certificate. If IE discovers that there is no root certificate after the user's PC connects to the camera, it will automatically redirect to VeriSign Web site to download and install the latest root certificate to make the installation successfully. If the user's computer is able to connect to camera but unable to access the internet, then the installation will fail because the computer will not be able to download the latest root certificate. This problem can be resolved if computer can be connect to the internet and the camera at the same time and will not recur when Windows update patches become available.

## Live View



**!** **NOTE** - (\*) These are optional features. Please refer to the Product List for the full list of optional features available for the product.

**Live View** is the default page that opens when accessing the camera. Live video is displayed directly in the browser window.

- **Stream1/Stream2 Channels**

The network camera offers simultaneous dual stream for optimized quality and bandwidth. Go to Configuration → Camera/Video/Audio → Video to configure the codec compression and video resolution or refer to the Video configuration page.

- **HTTP/TCP/UDP protocol**

**HTTP** – This unicast method can be used to traverse firewalls. Firewalls are commonly configured to allow the HTTP protocol, thus allowing RTP to be tunneled.

**TCP** - This protocol guarantees the complete delivery of streaming data and provides better video quality. The downside of using this protocol is that the quality of its real-time effect is less than that of the UDP protocol.

**UDP** - This protocol allows for more real-time audio and video streams. However, network packets may be lost due to network burst traffic and images may be broken. Activate UDP connection time-sensitive responses are more important than video quality.

**LED Control** – Use the drop-down menu to adjust the brightness of the camera's LED.



Recording on/off - Displays the status of recording video



MIC on /off - Displays the status of the MIC volume



Speaker on/off - Displays the status of the Speaker

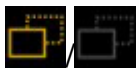

MD on/off - Displays the status of Motion Detection

- **Brightness** - Drag the slider bar to adjust the image brightness level.
- **Mic volume** - Drag the slider bar to adjust the microphone volume.
- **Speaker volume** - The built-in speaker will play sound from an audio clip from the computer microphone when it is enabled.

For more Audio settings, please refer to the Audio configuration page.



Player Stop - Play or stop the video.



Recording - Record video to a computer.



Snapshot - Capture and save still images.



Digital Zoom - Enable the digital zoom operation.

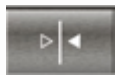

Mirror - Horizontally reflect the display of the live video.



Flip - Vertically reflect the display of the live video.

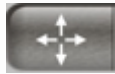

Real Size - View the object in real size. Press it again to switch back to normal mode.



Full Screen - Switch to full screen mode. Press the “Esc” key to return to normal mode.



Motion Detection Alert - Enable the motion detection alert function.



Mute – Turn off the sound.



Talk(\*) – To communicate through the camera using the computer MIC.



Set Default – Reset to default settings.



## NOTE

1. The <Camera Control Panel> functions have no effect on the recorded video. Whatever changes are made to the <Camera Control Panel> **will not** be applied to the recorded video.
2. The LED is not for continuous use and has an estimated life span of 30,000 hours.
3. The LED cannot be replaced.

## Configuration

Click <Configuration> on the main page to change the camera settings pages.



**NOTE** - Only Administrators can access the Configuration page.

### Camera/Video/Audio

#### Camera

The screenshot displays the camera configuration interface. On the left, a video feed shows a glass jar with a plant and cartoon figures. Below the feed are four sliders for Brightness, Contrast, Sharpness, and Saturation. On the right, a settings panel includes sections for Exposure Control (Sport, Normal, Night Vision, User Defined), De-Noise (Level 1), Mirror and Flip (Mirror, Flip), Flicker Free (Outdoor Mode, Indoor Mode - 50Hz, Indoor Mode - 60Hz), and Color Effect (Color, Black & White). At the bottom right are buttons for 'Test in Full Screen', 'Apply', and 'Cancel'.

**Brightness** - Drag the slider bar to adjust the image brightness level from -5 to +5.

**Contrast** - Drag the slider bar to adjust the image contrast level from -5 to +5.

**Sharpness** - Drag the slider bar to adjust the image sharpness level from -5 to +5.

**Saturation** - Drag the slider bar to adjust the image saturation level from -5 to +5.

## **Exposure Control**

**Sport** – Select this option when monitoring rapid moving objects.

**Normal** – Select this option for normal monitoring conditions.

**Night Vision** – Select this option when monitoring at night or in low light conditions.

**User Defined** – Select this option to define the exposure manually.

**AGC (Auto Gain Control)** - The AGC can be set between 1X to 5X. Set the Gain Rate higher for a better video illumination, with 5X giving the best video illumination.



**NOTE** - higher gain rate may cause a higher judder or blur on fast moving images.

## **Shutter Speed**

**Fast** – For high activity exposure function.

**Normal** – For normal exposure function.

**Slow** – For night vision exposure function.

**AE Lock (Auto Exposure)**: The camera will automatically adjust the exposure to the changes in ambient light.

## **De-Noise**

**Auto** - The camera will automatically filter the frame-to-frame defects to reduce the visual impact of blur.

The De-noise can be set between 1 to 3, with 3 giving the best video resolution.

## **Mirror and Flip**

**Mirror** - Enable to horizontally reflect the display of the live video.

**Flip** - Enable to vertically reflect the display of the live video.

**Flicker-Free** – Eliminate the problem of flicker.

Click the Radio button to select outdoor or indoor mode based on the conditions.

**Color Effect** - Select to display color or black and white video streams.

Click **Apply** to apply settings or **Cancel** to cancel changes.

## Video

The Network Camera offers two separate streams for different viewing options.

Stream	Video Overlay	RTSP Server	Save File Folder
<b>Stream 1</b>			
Enabled	<input checked="" type="checkbox"/>		
Video Codec	H.264		
Video Resolution	1280x800(WXGA)		
Frame Rate	25 fps		
<input type="radio"/> Quality <input checked="" type="radio"/> Bitrate	1500Kbps		
<b>Stream 2</b>			
Enabled	<input checked="" type="checkbox"/>		
Video Codec	MJPEG		
Video Resolution	1280x800(WXGA)		
Frame Rate	25 fps		
<input checked="" type="radio"/> Quality <input type="radio"/> Bitrate	3		
HTTP Transport	<input checked="" type="checkbox"/>		
<input type="button" value="Apply"/> <input type="button" value="Cancel"/>			

### Stream 1 & Stream 2

**Video Codec** - The Network Camera offers three choices of video codec standards for real-time viewing: H.264, MPEG-4 and MJPEG.

**Video Resolution** - Select from the drop-down menu to choose the best resolution recording settings.

**Frame Rate** - Select the frame rate from drop-down menu. When H.264 or MJPEG is selected, the frame rate ranges from 1 to 30 fps. When MPEG-4 is selected, the frame rate ranges from 1 to 15 fps. Set a higher frame rate for smoother video quality.

**Video quality and bit rate** - Choose either “quality” or “bitrate” to control the video quality with video codec at H.264 or MPEG4. Only “quality” can be chosen when video codec at MJPEG is selected. Set the bitrate higher for a better video quality.

 **NOTE** - a higher bitrate will use higher network bandwidth. The video quality can be set between Level 1 to Level 6, with Level 6 producing the best image quality.

**HTTP Transport** – If MJPEG is used for Video Codec, users can enable HTTP Transport protocol for video communication.

 **NOTE** – HTTP Transport is for non-IE browser used only.

Click **Apply** to apply settings or **Cancel** to cancel changes.

## Video Overlay

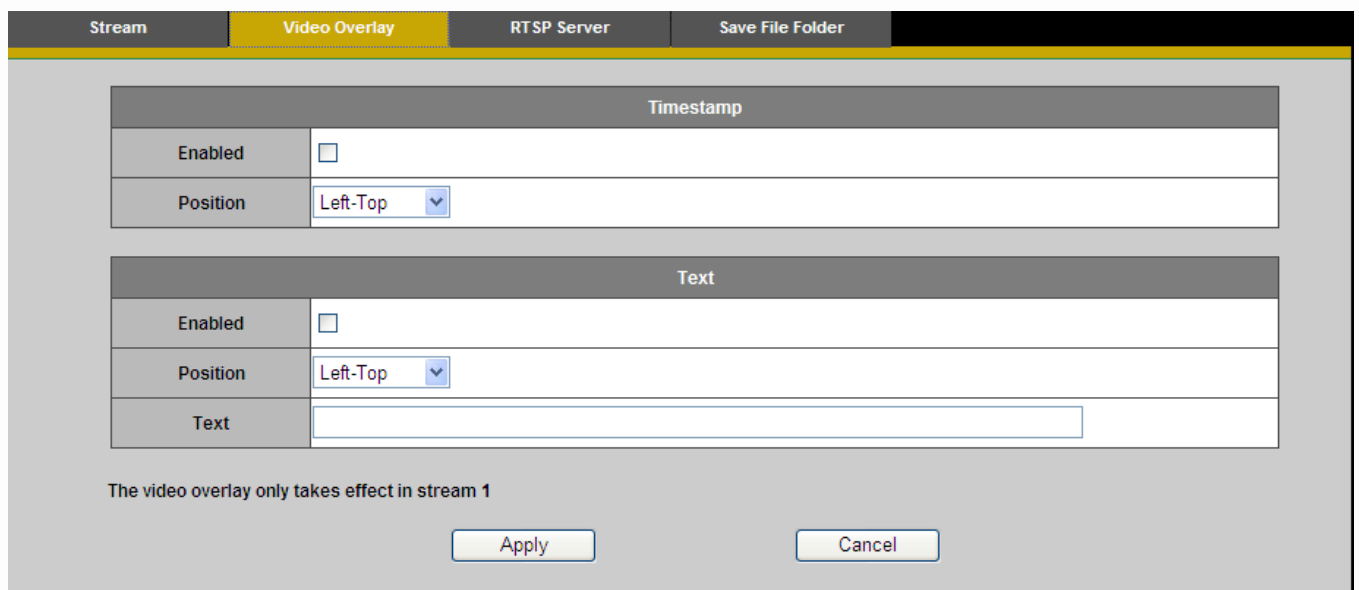

Timestamp	
Enabled	<input type="checkbox"/>
Position	Left-Top

Text	
Enabled	<input type="checkbox"/>
Position	Left-Top
Text	<input type="text"/>

The video overlay only takes effect in stream 1

Apply Cancel

### Timestamp

To display the date and time on the screen during live view, check “Enable” to enable the timestamp function and select the display position from the drop-down menu.

### Text

To make a note about the camera, check “Enable” and select the display position from the drop-down menu. Enter a video description in the text box.

Click **Apply** to apply settings or **Cancel** to cancel changes.

 **NOTE** - The video overlay will only takes effect in stream 1.



## RTSP Server

RTSP Server	
Port	554
Authentication	NONE

Apply Cancel

To utilize RTSP authentication, the user must first set a password for the camera. RTSP (Real-Time Streaming Protocol) controls the delivery of streaming media. By default the port number is set to 554.

**Authentication** - Depending on the network security requirements, the camera provides two types of security settings for streaming via RTSP protocol: NONE and DIGEST.

If DIGEST authentication is selected, user credentials are encrypted using MD5 algorithm, thus providing better protection against unauthorized access.

Click **Apply** to apply settings or **Cancel** to cancel changes.

## Save File Folder

Recording Folder Path	
Path	D:\My Documents\Brickcom

Snapshot Folder Path	
Path	D:\My Documents\Brickcom
Type	JPEG

Apply Cancel

**Recording folder path** - The destination for saving the recording video files. Click Browse to specify the saving path.

**Snapshot folder path** - The destination for saving the snapshot files. Click Browse to specify the saving path and select the format from the drop-down menu.

Click **Apply** to apply settings or **Cancel** to cancel changes.

## Audio

The administrator can set up two separate streams for the camera for different viewing devices.

The administrator can enable or disable the audio function on either stream. If audio enable is selected, select the Audio codec from the drop-down menu.

The screenshot shows the 'Advanced Settings' tab for audio configuration. It features two sections: 'Stream 1' and 'Stream 2'. Each section has an 'Enabled' checkbox and an 'Audio Codec' dropdown menu. Both 'Enabled' checkboxes are currently unchecked, and both 'Audio Codec' dropdowns are set to 'G.711'. At the bottom of the form, there are 'Apply' and 'Cancel' buttons.

## Advanced Settings

The screenshot shows the 'Advanced Settings' tab for camera audio configuration. It features two sections: 'Camera Speaker' and 'Echo Cancellation'. The 'Camera Speaker' section has an 'Enabled' checkbox (checked) and a 'Volume' dropdown menu (set to 50%). The 'Echo Cancellation' section has an 'Enabled' checkbox (unchecked). At the bottom of the form, there are 'Apply' and 'Cancel' buttons.

**Camera Speaker** – If the speaker is enabled, select the volume from the drop-down menu.

**Echo Cancellation Enabled** - Enable to avoid an echo.

Click **Apply** to apply settings or **Cancel** to cancel changes.

## Multicast

Multicast

Stream 1	
Enabled	<input type="checkbox"/>
Multicast Address	234 . 1 . 2 . 3 Port 10000

Stream 2	
Enabled	<input type="checkbox"/>
Multicast Address	234 . 1 . 2 . 3 Port 20000

Apply Cancel

Multicast sends a video stream to the multicast group address and allows multiple clients to acquire the stream at the same time by requesting a copy from the multicast group address. Therefore, multicast can effectively save Internet bandwidth. The RTSP (Real-Time Streaming Protocol) controls the delivery of streaming media.

Click "Enable" to enable Multicast stream 1 or Multicast stream 2. The default value for multicast address and port are 234.1.2.3 and 10000. Use different port number for different streams. It is recommended to use the default values.



**NOTE** - Using the IP address of the Network Camera enables access to the video.

Example: `rtsp://192.168.1.1/channel1`

Click **Apply** to apply settings or **Cancel** to cancel changes.

## Privacy Mask Control

The Cube camera is equipped with a privacy feature which allows users to disable the video recording when it is not needed. This application is particularly useful when the camera is being used for home surveillance. With the privacy button, the user can have privacy while they are going about their daily life.

Privacy Mask Control	
Enabled	<input type="checkbox"/>

Hardware Privacy Mask Button	
Enabled	<input checked="" type="checkbox"/>

Apply Cancel

**Privacy Mask Control** – Enable the Privacy Mask control to remotely disable live view and recording from the camera.

**Hardware Privacy Mask Button** – Click to enable the privacy mask button on the camera. If this feature is not enabled, the user will not be able to use the privacy mask button.



## Network

### IP Settings

This section explains how to configure a wired network connection for the camera. There are several ways to setup the camera over the Internet: (1) obtain an available dynamic IP address assigned by a DHCP server, (2) use a static IP, or use PPPoE (Point-to-point over Ethernet). Select the desire setup mode from the IP settings drop-down menu.

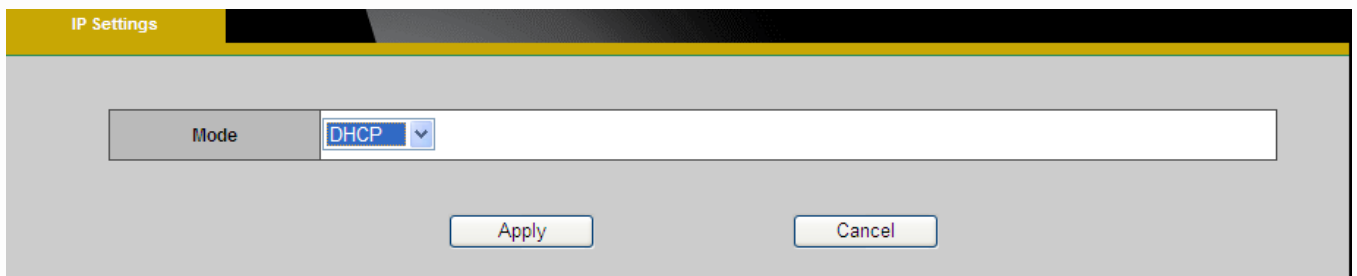

The screenshot shows the 'IP Settings' window with the 'Mode' dropdown menu set to 'DHCP'. Below the dropdown are 'Apply' and 'Cancel' buttons.

1. **DHCP** –If this option is selected, the camera will automatically obtain an available dynamic IP address from the DHCP server each time it connects to the LAN.

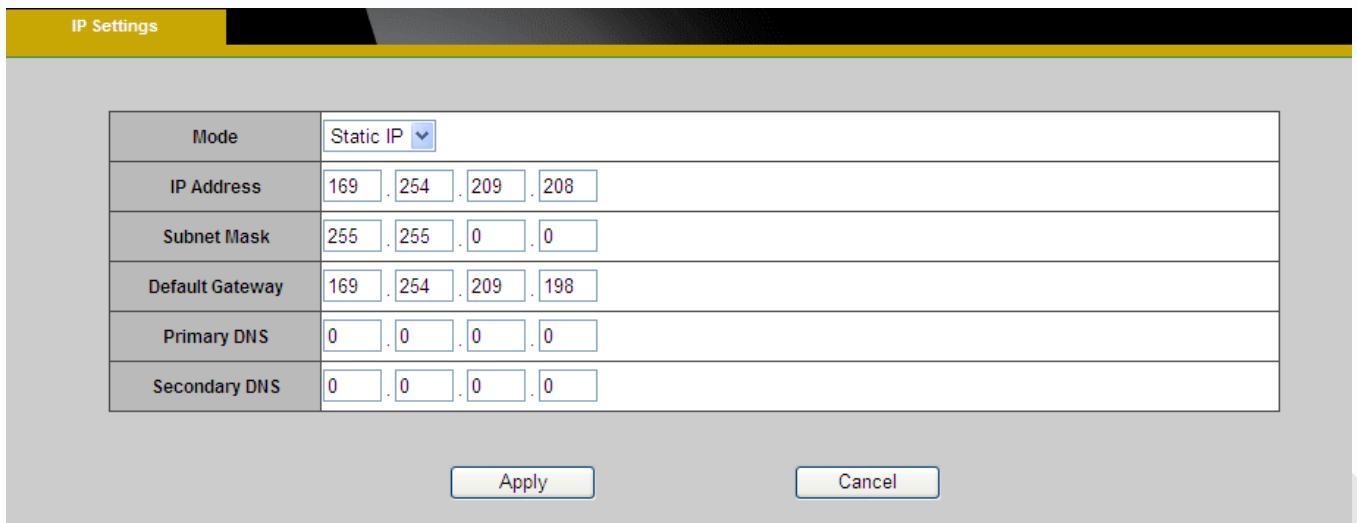

The screenshot shows the 'IP Settings' window with the 'Mode' dropdown menu set to 'Static IP'. Below the dropdown is a table for entering network configuration details, followed by 'Apply' and 'Cancel' buttons.

Mode	Static IP			
IP Address	169	254	209	208
Subnet Mask	255	255	0	0
Default Gateway	169	254	209	198
Primary DNS	0	0	0	0
Secondary DNS	0	0	0	0

2. **Static IP** - Select this option to manually assign a static IP address to the camera. Enter the static IP address, Subnet mask, Default Gateway, Primary and Secondary DNS provided by the ISP.

IP Settings	
Mode	PPPoE
Username	
Password	

Apply Cancel

3. **PPPoE** (Point-to-point over Ethernet): Use this mode if connecting to the Internet through a DSL Line.  **NOTE** - To utilize this feature, it requires an account provided by an Internet Service Provider. Enter the user name and password provided by the ISP. Click **Apply** to apply settings or **Cancel** to cancel changes.

## UPnP

Universal Plug and Play (UPnP) simplifies the process of adding a camera to a local area network. Once connected to a LAN, the camera will automatically appear on the intranet. Click “Enable” to enable this function and enter an UPnP name which the camera will appear under on the intranet.

UPnP	
Enabled	<input checked="" type="checkbox"/>
UPnP Name	WCB-100Ap-2c11

Apply Cancel

Click **Apply** to apply settings or **Cancel** to cancel changes.

## DDNS (dynamic domain name service)

DDNS links a domain name to an IP address, allowing users to easily access their camera even with a changing IP address. Brickcom network cameras are compatible with two DDNS service providers (1) DynDNS, and (2) TZO.  **NOTE** - Before utilizing this function; please apply for a dynamic domain account from a DDNS provider.

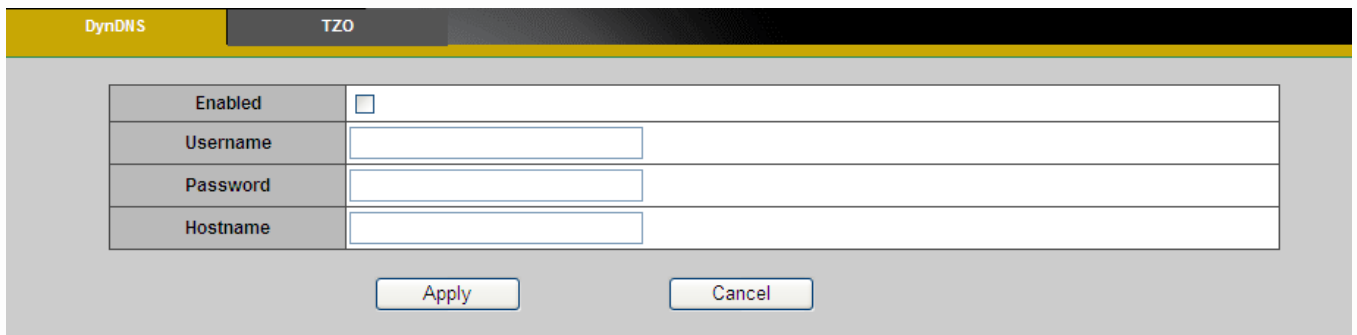

DynDNS	
Enabled	<input type="checkbox"/>
Username	<input type="text"/>
Password	<input type="text"/>
Hostname	<input type="text"/>
<input type="button" value="Apply"/> <input type="button" value="Cancel"/>	

**DynDNS** – Enable the DynDNS to allow the camera to have a fixed host and domain name. Refer to the DynDNS website ([www.dyndns.com](http://www.dyndns.com)) to apply for a dynamic domain account. When an account has been created, enter the username, password and hostname. Click **Apply** to apply settings or **Cancel** to cancel changes.

## TZO

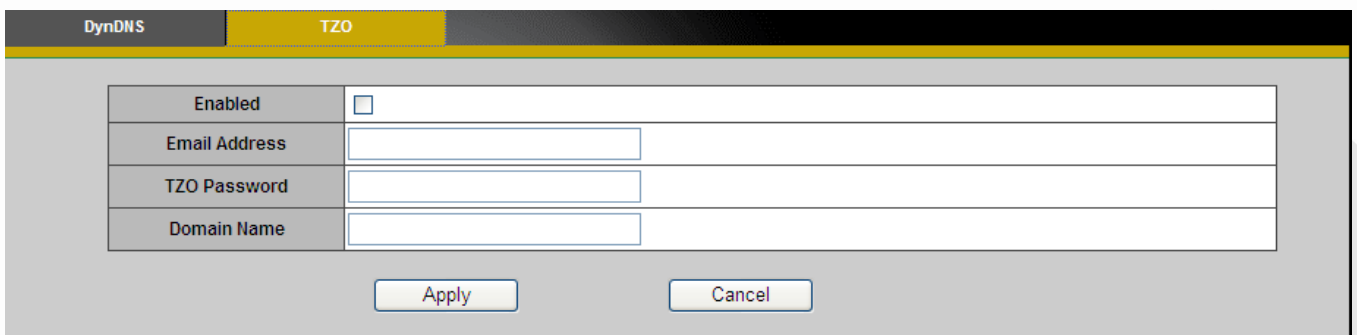

TZO	
Enabled	<input type="checkbox"/>
Email Address	<input type="text"/>
TZO Password	<input type="text"/>
Domain Name	<input type="text"/>
<input type="button" value="Apply"/> <input type="button" value="Cancel"/>	

**TZO** is a DDNS provider which allows users to create a dynamic DNS. Refer to the TZO website (<http://www.tzo.com/>) to apply for a dynamic domain account. When an account has been created, enter the e-mail address, password and domain name.

Click **Apply** to apply settings or **Cancel** to cancel changes.

## EasyLink™

EasyLink™ is a unique Brickcom function which allows users to assign a unique domain name to their network camera's IP address. There is no need to configure the router to open up ports or remember hard-to-memorize IP addresses. When this function is enabled, users can log onto [uniquedomainname].mybrickcom.com to view the camera's web GUI and live view.

1. Check the box to enable EasyLink™.
2. Enter a unique domain name whose length must be between 5-32 characters. Verify that the domain name is available.
3. Select a desired amount of time from the Refresh Time drop-down menu to confirm the connection status.

Enabled	<input checked="" type="checkbox"/>
Domain Name	<input type="text" value="002682592c11"/> .mybrickcom.com <input type="button" value="Verify"/>
Refresh Time	<input type="text" value="5 Min"/> ▾
EasyLink Status	Registration successful.

Click **Apply** to apply settings or **Cancel** to cancel changes.



**NOTE** - The EasyLink function will not work if the following conditions occur:

1. The camera cannot be located behind a double NAT network.
2. The camera's IP address cannot be assigned to specific port numbers using the router's port forwarding.
3. EasyLink uses UPnP to exchange port information with the router. The camera must connect to the internet through a router which supports UPnP.



## Wireless

These settings control how a Network Camera interacts with a wireless network. Users can identify the wireless network and enable wireless encryption.



**NOTE** – This function is only available for WCB models.

### Basic Settings

The screenshot shows the 'Basic Settings' tab selected. The 'Network Name (SSID)' field is set to 'Brickcom' with a 'Site survey' button next to it. The 'Security' dropdown menu is open, showing options: 'Disabled' (selected), 'WEP', 'WPA-Personal', and 'WPA2-Personal'. There are 'Apply' and 'Cancel' buttons. Below the settings is a 'Site Survey List' section with a message: 'Click the Site Survey Button to update the list.'

**Network Name (SSID)** - The Service Set Identifier (SSID) is the network name used to identify the wireless signal emitted from a wireless camera. It is case-sensitive and can be up to 32 characters long.

Wireless devices have a default SSID set by the factory. Brickcom wireless products use **Brickcom** as the default name. It is recommended for users to rename their SSID to something unique in order to distinguish their wireless device from surrounding wireless networks.



**NOTE** - Be careful when including personal information when naming the SSID as it is viewable by anyone browsing for wireless networks.

**Security** - Encryption protects data transmitted over a wireless network. Wi-Fi Protected Access (WPA-Personal/WPA2-personal) and Wired Equivalent Privacy (WEP) offer different levels of security for wireless communication. A network encrypted with WPA-Personal/WPA2-personal is more secure than a network encrypted with WEP because WPA-Personal/WPA2-personal uses dynamic key encryption. To protect the information as it passes through the airwaves, it is recommended to enable the highest level of encryption supported by the network equipment.

**Site Survey** – Survey the local area for available wireless networks. The user should select their Local Area Network (LAN) from the Site Survey List.

The screenshot shows the 'Wi-Fi Protected Setup' configuration page. At the top, there are three tabs: 'Basic Settings', 'Advanced Settings', and 'Wi-Fi Protected Setup'. The 'Network Name (SSID)' field contains 'Brickcom' and has a 'Site survey' button next to it. The 'Security' dropdown menu is set to 'Disabled'. Below these fields are 'Apply' and 'Cancel' buttons. A 'Site Survey List' table is displayed below, listing detected wireless networks.

SSID	Mode	Security	Channel	Signal	Type	Select
test_gary_Brickcom_1	11b/g/n	NONE	1	78%	Infrastructure	Select
SmartHub-AWRT600N	11b/g/n	NONE	1	73%	Infrastructure	Select
Test-FAE	11b/g/n	NONE	1	100%	Infrastructure	Select
bricom_3	11b/g/n	NONE	1	89%	Infrastructure	Select
Test_Cavin	11b/g	NONE	1	57%	Infrastructure	Select
PC N/B TEST	11b/g/n	NONE	2	88%	Infrastructure	Select

**WEP**- Wired Equivalent Privacy (WEP) is a basic encryption method which transmits network broadcast messages using radio signals. It is not as secure as WPA.

The screenshot shows the 'Wi-Fi Protected Setup' tab in the router's configuration interface. The 'WEP' security settings are configured as follows:

Network Name (SSID)	Brickcom	Site survey
Security	WEP	
TX Key	1	
WEP Encryption	40/64 bits (10 hex digits)	
Key 1		
Key 2		
Key 3		
Key 4		
Authentication	Open System	

Buttons for 'Apply' and 'Cancel' are located below the settings form.

The 'Site Survey List' table below shows the following data:

SSID	Mode	Security	Channel	Signal	Type	Select
test_gary_Brickcom_1	11b/g/n	NONE	1	78%	Infrastructure	Select
SmartHub-AWRT600N	11b/g/n	NONE	1	73%	Infrastructure	Select
Test-FAE	11b/g/n	NONE	1	100%	Infrastructure	Select
bricom_3	11b/g/n	NONE	1	89%	Infrastructure	Select
Test_Cavin	11b/g	NONE	1	57%	Infrastructure	Select
PC-MIP-TEST	11b/g/n	NONE	2	68%	Infrastructure	Select

**Tx Key** - Select a key from the drop-down menu.

**WEP Encryption** - Select a level of WEP encryption: 64 bits 10 hex digits or 128 bits 26 hex digits. The default is 64 bits 10 hex digits.

**Key 1-4** - Enter the WEP key(s) manually.

**Authentication** - The default is set to Open System, which allows either Shared Key or Auto authentication to be used. With Shared Key authentication, the sender and recipient use a WEP key for authentication. With Auto authentication, the sender and the recipient do not use a WEP key for authentication.

Click **Apply** to apply settings or **Cancel** to cancel changes.

## WPA-Personal - WiFi Protected Access (WPA)-Personal

SSID	Mode	Security	Channel	Signal	Type	Select
test_gary_Brickcom_1	11b/g/n	NONE	1	78%	Infrastructure	Select
SmartHub-AWRT600N	11b/g/n	NONE	1	73%	Infrastructure	Select
Test-FAE	11b/g/n	NONE	1	100%	Infrastructure	Select
bricom_3	11b/g/n	NONE	1	89%	Infrastructure	Select
Test_Cavin	11b/g	NONE	1	57%	Infrastructure	Select
PC-NVB-TEST	11b/g/n	NONE	2	68%	Infrastructure	Select

**Encryption** - Supports two encryption methods with dynamic encryption keys: Temporal Key Integrity Protocol (TKIP) and Advanced Encryption Standard (AES). Select the algorithm type from the drop down menu: TKIP or AES. The default is TKIP.

**Shared Key** - Enter the key shared between the Router and the server keys. Enter a password of 8-63 characters.

Click **Apply** to apply settings or **Cancel** to cancel changes.

## WPA2-Persona I - WiFi Protected Access (WPA2-Personal)

Basic Settings | **Advanced Settings** | Wi-Fi Protected Setup

Network Name (SSID)	Brickcom	Site survey
Security	WPA2-Personal	
Encryption	AES	
Shared Key	<input type="text"/> (8 to 63 characters)	

Apply | Cancel

Site Survey List						
SSID	Mode	Security	Channel	Signal	Type	Select
test_gary_Brickcom_1	11b/g/n	NONE	1	78%	Infrastructure	Select
SmartHub-AWRT600N	11b/g/n	NONE	1	73%	Infrastructure	Select
Test-FAE	11b/g/n	NONE	1	100%	Infrastructure	Select
bricom_3	11b/g/n	NONE	1	89%	Infrastructure	Select
Test_Cavin	11b/g	NONE	1	57%	Infrastructure	Select
PC-MVP-TEST	11b/g/n	NONE	2	68%	Infrastructure	Select

**Encryption** - WPA2 supports AES encryption method with dynamic encryption keys.

**Shared Key** - Enter the key shared between the Router and the server keys. Enter a password of 8-63 characters.



**NOTE** - If using WPA or WPA2, each device in the wireless network must use the same WPA or WPA2 method and shared key or else the network will not function properly.

## Advanced Settings

Basic Settings	Advanced Settings	Wi-Fi Protected Setup
Network Mode	BGN-Mixed	
Radio Band	Auto-20/40MHz Channel	
WMM (802.1e QoS)	Disabled	

**Network Mode** - From the drop-down menu, select the wireless standards running on the network.

- If there are Wireless-B, Wireless-G and Wireless-N (2.4GHz) devices on the network, use the default setting, **BGN-Mixed**.
- If there are Wireless-B and Wireless-G devices on the network, select **BG-Mixed**.
- If there are only Wireless-B devices on the network, select **Wireless-B Only**.
- If there are only Wireless-G devices on the network, select **Wireless-G Only**.
- If there are only Wireless-N (2.4GHz) devices on the network, select **Wireless-N Only**.
- (\*) If there are Wireless-A and Wireless-N devices on the network, select **AN-Mixed**.
- (\*) If there are Wireless-A, Wireless-B, Wireless-G and Wireless-N (2.4GHz) devices on the network, use the default setting, **ABGN-Mixed**.
- (\*) If there are only Wireless-A devices on the network, select **Wireless-A Only**.

**Radio Band** - The settings are available for the Auto-20/40MHz channel and Standard-20 MHz channel.

**Enable WMM (802.1e QoS)** - WMM is a wireless Quality of Service feature that improves quality for audio, video, and voice applications by prioritizing wireless traffic. To use this feature, the wireless client devices on the network must support Wireless WMM. The default setting is **Enabled**. To disable this feature, select **Disable**.

Click **Apply** to apply settings or **Cancel** to cancel changes

## Wi-Fi Protected Setup

Basic Settings	Advanced Settings	Wi-Fi Protected Setup
<b>Wi-Fi Protected Setup</b>		
<b>PIN Mode</b>	Enter PIN number 38989827 in the AP device Enter the AP's SSID   Brickcom Click the Register button on the right to start WPS. <input type="button" value="Register"/>	
<b>Wi-Fi Protected Setup Status</b>	Not Configured	
<b>Hardware WPS Button</b>		
<b>Enabled</b>	<input checked="" type="checkbox"/>	
<input type="button" value="Apply"/> <input type="button" value="Cancel"/>		

Use this method if the client device has a Wi-Fi Protected Setup PIN number.

1. Enter the network name from the device in the field.
2. Click <Register> to start WPS.
3. Click "Enable" to enable the WPS Button. If this feature is not enabled, the user will not be able to use the WPS button

Click **Apply** to apply settings or **Cancel** to cancel changes.



## HTTP/HTTPS

HTTP	
Enabled	<input checked="" type="checkbox"/>
Port	80

HTTPS	
Enabled	<input type="checkbox"/>
Port	443

**HTTP** – (HyperText Transfer Protocol) - This protocol allows for TCP protocol quality without having to open specific ports for streaming. Users inside a firewall can utilize this protocol to allow streaming data through.

**HTTPS** - (Hypertext Transfer Protocol over SSL) - This protocol allows authentication and encrypted communication over SSL (Secure Socket Layer). It helps protect streaming data transmission over the Internet on a higher security level than HTTP.

Click “Enable” to enable and **Apply** to apply settings or **Cancel** to cancel changes.

To enable HTTPS, users have to create and install a certificate.

1. Click “Continue to this website” to install.





2. Enter the User name and Password of the camera



3. Click "Certificate Error" on the top right corner of the window to view the certificate.



4. Click "Install Certificate" and follow the steps to finish the installation.

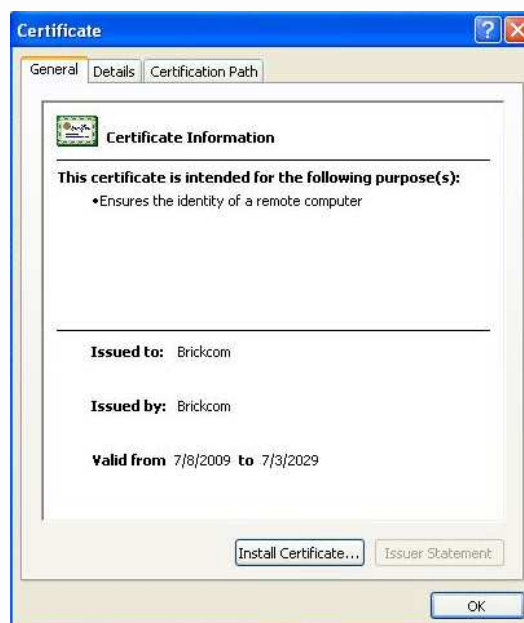

## Event

### Event Settings

When an event (such as unauthorized movement) occurs, the camera can be scheduled to perform certain actions. An Event Type is a set of parameters that defines these actions.

This section describes how to configure the camera to perform certain actions when events occur.

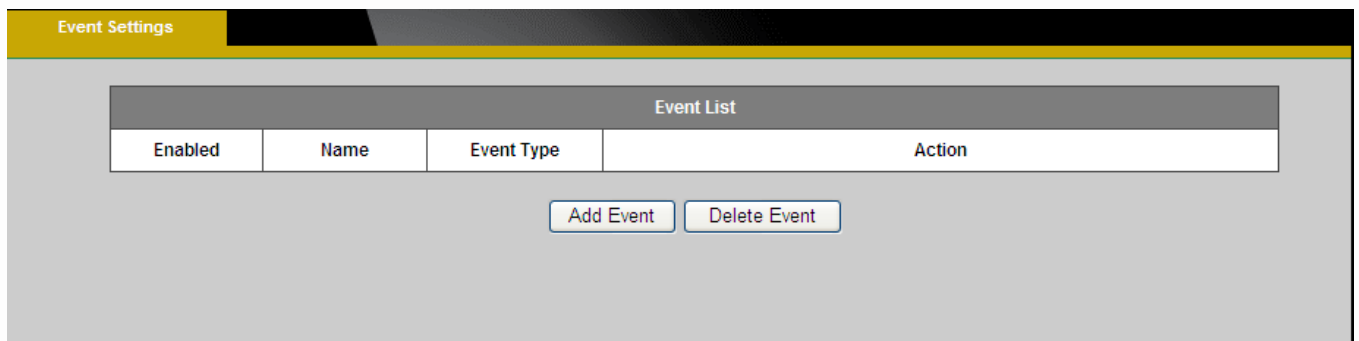

Click <Add Event> on the Event Settings page. The Event Setup page will appear.

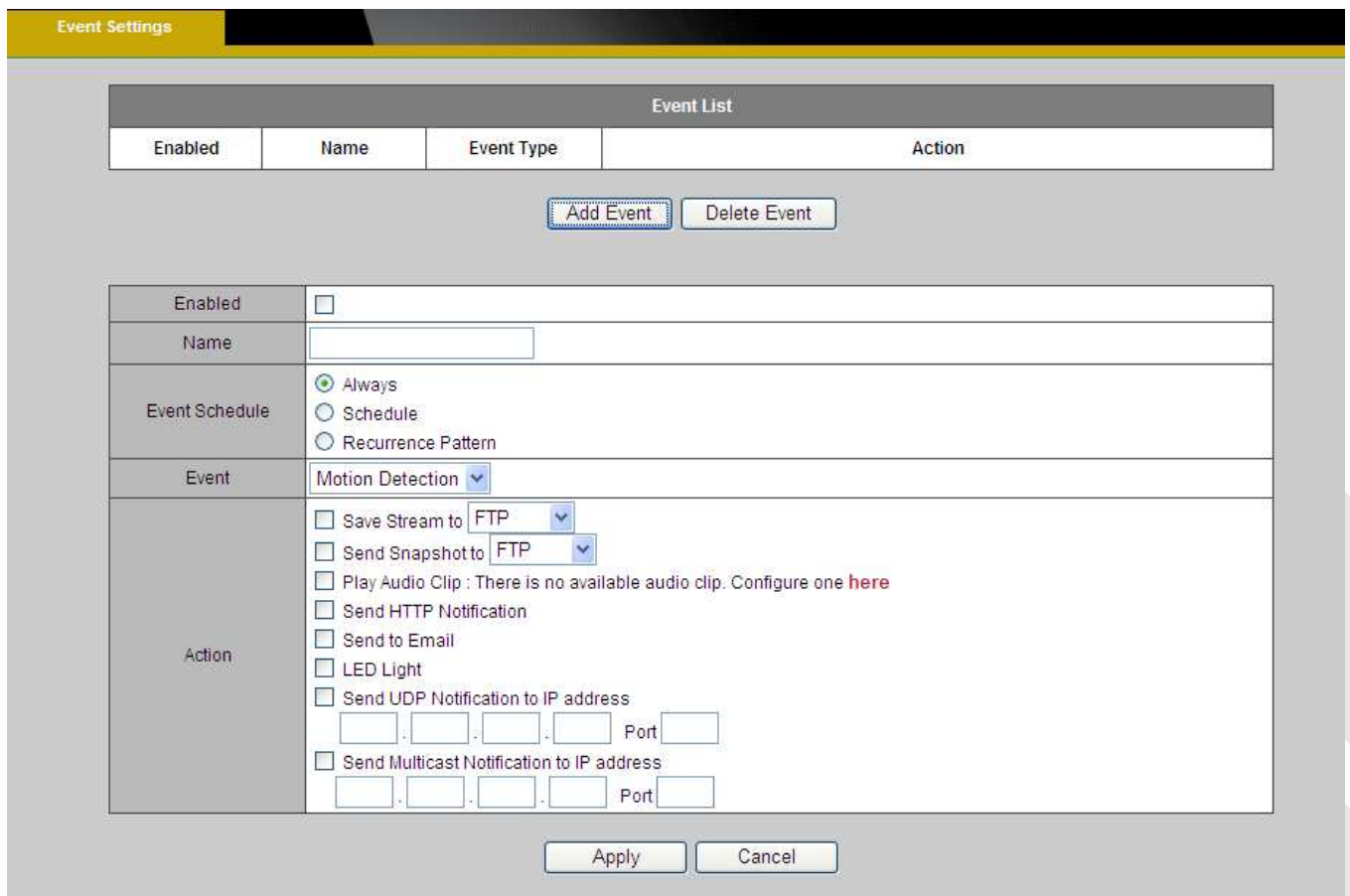

## How to Set Up an Event Schedule

Event Schedule describes how and when the camera performs certain actions.

1. Check “Enable” and enter a descriptive name for the event schedule.
2. Set Event Schedule to define when the event is activated by selecting from Always (24 hours), Schedule or Recurrence pattern.

- a. If Schedule is selected from the Event Schedule, the following page will be displayed:

The screenshot shows the 'Event Schedule' configuration interface. It includes an 'Enabled' checkbox, a 'Name' field, and three radio button options: 'Always', 'Schedule' (selected), and 'Recurrence Pattern'. Below these is a calendar grid with columns for 0:00, 6:00, 12:00, 18:00, and 24:00, and rows for Sun, Mon, Tue, Wed, Thu, Fri, and Sat. Green squares indicate scheduled events. A legend shows a green square for 'Event Schedule' and a white square for 'Not Scheduled'. Buttons for 'Select All', 'Clear All', and 'Undo All' are present. The 'Event' dropdown is set to 'Motion Detection'. The 'Action' section contains several checkboxes for actions like 'Save Stream to FTP', 'Send Snapshot to FTP', 'Play Audio Clip', 'Send HTTP Notification', 'Send to Email', 'LED Light', 'Send UDP Notification to IP address', and 'Send Multicast Notification to IP address'. At the bottom are 'Apply' and 'Cancel' buttons.

- i. A Scheduled Event can be programmed for certain times and day. Click individual boxes to schedule specific times for the camera to detect events.

b. If Recurrence Pattern is selected, the following page will be displayed.

Event Settings

Event List			
Enabled	Name	Event Type	Action
<input checked="" type="checkbox"/>	12345	Motion Detection	Send to Email
<input checked="" type="checkbox"/>	abcde	PIR	Take Snapshot
<input checked="" type="checkbox"/>	asdf	Audio	LED Light

Add Event
Delete Event

Enabled	<input checked="" type="checkbox"/>
Name	<input type="text" value="asdf"/>
Event Schedule	<input type="radio"/> Always <input type="radio"/> Schedule <input checked="" type="radio"/> Recurrence Pattern Sun <input checked="" type="checkbox"/> Mon <input type="checkbox"/> Tue <input type="checkbox"/> Wed <input checked="" type="checkbox"/> Thu <input type="checkbox"/> Fri <input type="checkbox"/> Sat <input type="checkbox"/> Start <input type="text" value="00"/> : <input type="text" value="07"/> Duration <input type="text" value="10"/> Minutes
Event	Audio Detection <input type="button" value="v"/>
Action	<input type="checkbox"/> Save Stream to <input type="button" value="v"/> SD card <input type="button" value="v"/> <input type="checkbox"/> Send Snapshot to <input type="button" value="v"/> FTP <input type="button" value="v"/> <input type="checkbox"/> Play Audio Clip : There is no available audio clip. Configure one <a href="#">here</a> <input type="checkbox"/> Send HTTP Notification <input type="checkbox"/> Send to Email <input checked="" type="checkbox"/> LED Light <input type="checkbox"/> Send UDP Notification to IP address <input type="text"/> . <input type="text"/> . <input type="text"/> . <input type="text"/> Port <input type="text"/> <input type="checkbox"/> Send Multicast Notification to IP address <input type="text"/> . <input type="text"/> . <input type="text"/> . <input type="text"/> Port <input type="text"/>

Apply
Cancel

- i. An event schedule can be programmed to recur at different times according to the user's needs. Select the days for the event schedule to occur. Select a start time and specify the duration.
3. Define what will trigger an event to occur by selecting an option from the Event drop-down list.
4. Select the Actions that will occur when the event is triggered.

a. When <Send to Email> is selected, the following page will be shown:

Enabled	<input type="checkbox"/>
Name	<input type="text"/>
Event Schedule	<input type="radio"/> Always <input type="radio"/> Schedule <input checked="" type="radio"/> Recurrence Pattern Sun <input type="checkbox"/> Mon <input type="checkbox"/> Tue <input type="checkbox"/> Wed <input type="checkbox"/> Thu <input type="checkbox"/> Fri <input type="checkbox"/> Sat <input type="checkbox"/> Start <input type="text"/> : <input type="text"/> Duration <input type="text"/> Minutes
Event	<input type="text" value="Motion Detection"/>
Action	<input type="checkbox"/> Save Stream to <input type="text" value="FTP"/> <input type="checkbox"/> Send Snapshot to <input type="text" value="FTP"/> <input type="checkbox"/> Play Audio Clip : There is no available audio clip. Configure one <a href="#">here</a> <input type="checkbox"/> Send HTTP Notification <input checked="" type="checkbox"/> Send to Email <input type="checkbox"/> LED Light <input type="checkbox"/> Send UDP Notification to IP address <input type="text"/> . <input type="text"/> . <input type="text"/> . <input type="text"/> Port <input type="text"/> <input type="checkbox"/> Send Multicast Notification to IP address <input type="text"/> . <input type="text"/> . <input type="text"/> . <input type="text"/> Port <input type="text"/>
Email	From <input type="text"/> To <input type="text"/> CC <input type="text"/> My Name <input type="text"/> Subject <input type="text"/>

- i. From - Enter the email address of the sender.
  - ii. To - Enter the email address of the recipient. To enter multiple recipients, separate each using a comma.
  - iii. Enter the sender's name that will appear in the recipient's inbox.
  - iv. Subject - Enter the title of the email.
5. When complete, click **Apply** to save new event or **Cancel** to delete the event. The new event will appear on the event list.
  6. To edit an event setting; select the event from the list. To remove an event setting from the list, select an event name from the list and then click <Delete Event>. Click <Add Event> to add more events.

 **NOTE** - Refer to the Audio Clip section for more details about the "Play Audio Clip" action.

## Motion Detection

Motion can be detected by measuring changes in the speed or vector of an object or objects in the monitored area. This section explains how to configure the Network Camera to enable motion detection.

**Detection Settings**

**Region Settings**

- Enable Window 1
- Enable Window 2
- Enable Window 3

Sensitivity

Threshold

Use the mouse to resize or move the Motion Detection Window. This chart records the amount of activity within the Motion Detection Window. When the activity level is above the threshold, the user will be notified.

※The MD setting is only activate in stream 1 .

Apply Cancel

**Detection Setting** – Use this setting to enable and define the motion detection windows. The user can defined up to three areas on the live view window for motion detection.

1. Select <Win1>, <Win2>, or <Win3> to adjust the motion detection window.
2. Check the box to enable the window.
3. Use the mouse to resize or move the motion detection window.
4. Adjust the “Sensitivity” level. Lower sensitivity levels will result in more activity needed to trigger an event.
5. Adjust the “Threshold” to change the threshold level. The higher the threshold, the larger objects need to be to trigger an event.

- The chart below the Live View window indicates the activity level of the Motion Detection window. When motion is detected by the camera and exceeds the defined threshold, a red bar will appear. Users can use this feature as a trigger source to send photos or videos to a remote server via email or FTP.

Click **Apply** to apply settings or **Cancel** to cancel changes.

## PIR(\*)

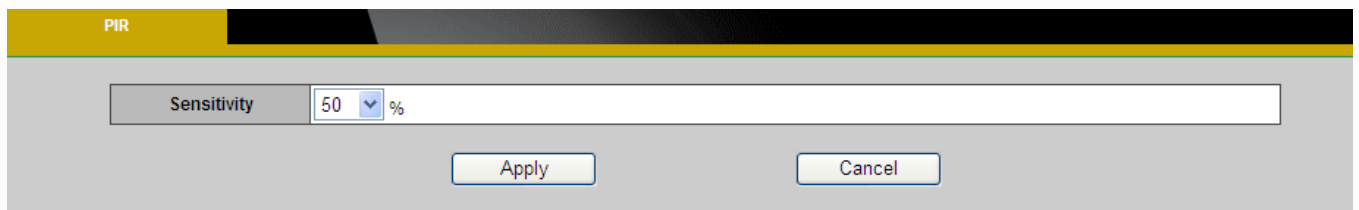

The screenshot shows a configuration window for the PIR sensor. It features a yellow header bar with the text 'PIR'. Below the header, there is a 'Sensitivity' label followed by a dropdown menu currently displaying '50' and a '%' sign. At the bottom of the window, there are two buttons: 'Apply' and 'Cancel'.

The PIR (Passive InfraRed) sensor measures infrared light radiating from objects in its field of view. This can be used to detect a moving object, such as a person, in dimly lit areas.

**Sensitivity** – Adjust the sensitivity of the PIR Sensor from the drop down menu. The sensitivity can be set from 10 - 100%; with the default sensitivity set at 50%. Higher sensitivity levels will increase the range of the PIR Sensor. When the sensitivity level is set to 100%, the PIR sensor will be able to detect moving objects within six meters.



## Audio Detection

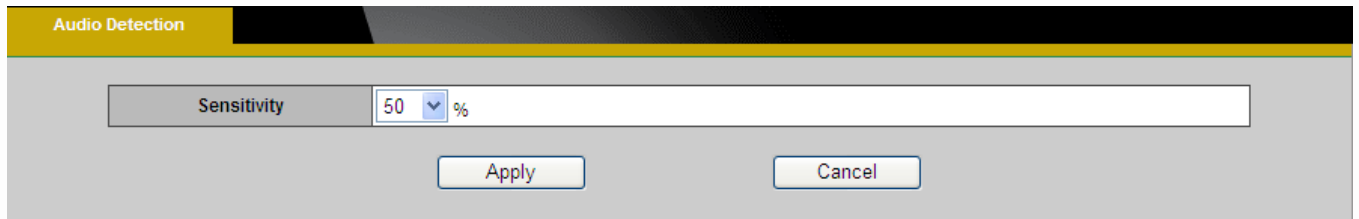

The screenshot shows a settings window titled "Audio Detection". It has a yellow header bar. Below the header, there is a form with a "Sensitivity" label, a dropdown menu set to "50", and a "%" symbol. At the bottom of the form, there are two buttons: "Apply" and "Cancel".

Users can schedule an event to be triggered if there is a change in the sound level of a monitored area. Audio detection can be used to measure change in the ambient voice. Select the sensitivity from the drop-down menu.

Sensitivity - is used to adjust the sensitivity of the sound level from 10 - 100%. The default sensitivity is 50%.

Click **Apply** to apply settings or **Cancel** to cancel changes.





## Notifications

Use the tools in this section to specify what type of notification will be sent when an event occurs. The camera can send buffered images to an FTP server, Samba, Email, or HTTP.

### FTP Settings

File Transfer Protocol (FTP) is used as an application component to automatically transfer files for program internal functions. Select “Primary FTP Server” from the Server Selection drop down menu to send media files to a FTP server when an event is triggered. Enter the FTP IP address or hostname. By default, the FTP port server is set to 21. Enter the account name, password and FTP Path to configure the settings.

FTP Settings	
Server Selection	Primary FTP Server
FTP Address	IP Address 0 . 0 . 0 . 0
FTP Port	21
Account Name	
Account Password	
FTP Path	

Apply Test Cancel

Click **Apply** to apply settings or **Cancel** to cancel changes.

## E-mail Settings

Select “Primary Email Server” option from the Server Selection drop down menu to send media files to an email server when an event is triggered.

SMTP Server - Enter the server host name of the email server.

SMTP Port - Enter the port number of the email server; by default, the SMTP port is set to 25.

Authentication - Select the authentication type from the drop-down menu.

Email Account - Enter the user name of the email account if necessary.

Email Password - Enter the password of the email account if necessary.

Email Settings	
Server Selection	Primary Email Server
SMTP Server	
SMTP Port	25
Authentication	LOGIN
Email Account	
Email Password	

Apply Test Cancel

Click **Apply** to apply settings or **Cancel** to cancel changes.



## Samba Settings

Select this option to send the media files via a network neighborhood when an event is triggered.

Server Address - Enter the IP address of the Samba server.

User Name - Enter the user name of the Samba server.

Password - Enter the password of the Samba server.

Workgroup - Enter the workgroup of the Samba server.

Shared Folder - Enter the share folder of the Samba server.

Samba Settings	
Server Address	IP Address [v] 0 . 0 . 0 . 0
Username	<input type="text"/>
Password	<input type="text"/>
WorkGroup	<input type="text"/>
Shared Folder	<input type="text"/>

Apply Test Cancel

Click **Apply** to apply settings or **Cancel** to cancel changes.



## HTTP Settings

Select this option to send the media files via an HTTP notification when an event is triggered.

HTTP Settings	
URL	<input type="text"/>
Message	<input type="text"/>
Username	<input type="text"/>
Password	<input type="text"/>

**URL** –Specify the URL to send HTTP requests. The URL is normally written as:

[http://ip\\_address/ notification.cgi?parameter](http://ip_address/notification.cgi?parameter)

ip\_address – type the IP address or host name of the HTTP host.

Parameter – type the notification parameter if necessary.

Example

URL - <http://192.168.1.1/xxxx.cgi>

Message - name1=value1&name2=vlaue2

Result - [http://192.168.1.1/xxxx.cgi? name1=value1&name2=vlaue2](http://192.168.1.1/xxxx.cgi?name1=value1&name2=vlaue2)

Ex:

<https://192.168.1.1/notification.cgi?event=MD&camera=FB-100A>

**Message** - Enter the message notification that will be sent when an event is triggered.

Enter the user name and password if necessary.

Click **Apply** to apply settings or **Cancel** to cancel changes.

## Video Clip

Video Clip	
Pre-Alarm Buffer	<input type="text" value="5"/> Seconds (0-10)
Post-Alarm Buffer	<input type="text" value="5"/> Seconds (0-30)
Maximum Buffer Size	<input type="text" value="1024"/> Kbytes (128-1500)

This function is used to determine when video clips will be recorded and stored after an event is triggered.

**Pre-alarm buffer** - Images can be stored internally on the server from the time immediately preceding the trigger. Enter the desired length of time.

**Post-alarm buffer** - Images can be stored internally on the server from the time immediately following the trigger. Enter the desired length of time.

**Maximum buffer size** –Specify the maximum file size allowed.

Click **Apply** to apply settings or **Cancel** to cancel changes.



## Audio Clip(\*)

Audio Recording – Audio clips can be recording and played when an event occurs.

The screenshot displays the 'Audio Recording' interface. At the top, there is a yellow header with the text 'Audio Recording'. Below this is a section titled 'Audio Clip List' containing a table with two columns: 'Index' and 'File Name'. The first row of the table is highlighted in cyan and contains the values '1' and '11111.wav'. Below the table are four buttons: 'Play', 'Stop', 'Delete', and 'Export'. Underneath these buttons is an 'Import' section with the text 'Please select a file to import' followed by a text input field, a 'Browse...' button, and an 'Import' button. At the bottom is the 'Audio Recording Settings' section, which includes a 'File Name' text input field, a 'Duration' dropdown menu set to '5' with a 'Second' label, and a 'Record' button.

Click **Browse** to import a file from a local hard drive or network disk. Select the file and click **Import**.  **NOTE** – The camera can only play audio clips which are saved as .wav files with G.711 u-law encoding in 8000 Hz sampling rate.

To record a new clip using the camera's microphone:

1. File Name - Enter a file name.
2. Duration - Enter the number of seconds to record.
3. Click **Record** to record the new audio clip.
4. The new audio clip will appear on the audio clip list.
5. Select an audio clip file from the Audio Clip List.
  - a. Play- Select to hear the audio clip
  - b. Stop- Select to stop playing the audio clip.
  - c. Delete- Select to delete an audio clip.
  - d. Export- Select to export the audio clip to a local hard drive or network disk.

## LED Light(\*)

LED Light	
Mode	<input checked="" type="radio"/> Keep active during event <input type="radio"/> Keep active for <input type="text" value="0"/> Sec
LED Control	Activate <input type="text" value="On"/> Inactivate <input type="text" value="OFF"/>

Apply Cancel

Mode – Select “Keep active during event” or “Keep active for” a specific amount of time when an event is triggered.

LED Control - The LED on the front of the camera can be set to flash at a configurable interval when an event is triggered. From the Activate drop down menu, select a percentage which the LED will brighten to. When the LED reaches the selected percentage, it can be configured to fade to off or turn off. Select the option from the Inactive menu.

Click **Apply** to apply settings or **Cancel** to cancel changes.

## System

### System Log

**Log** – Set up the camera to record a system log when an event is triggered.

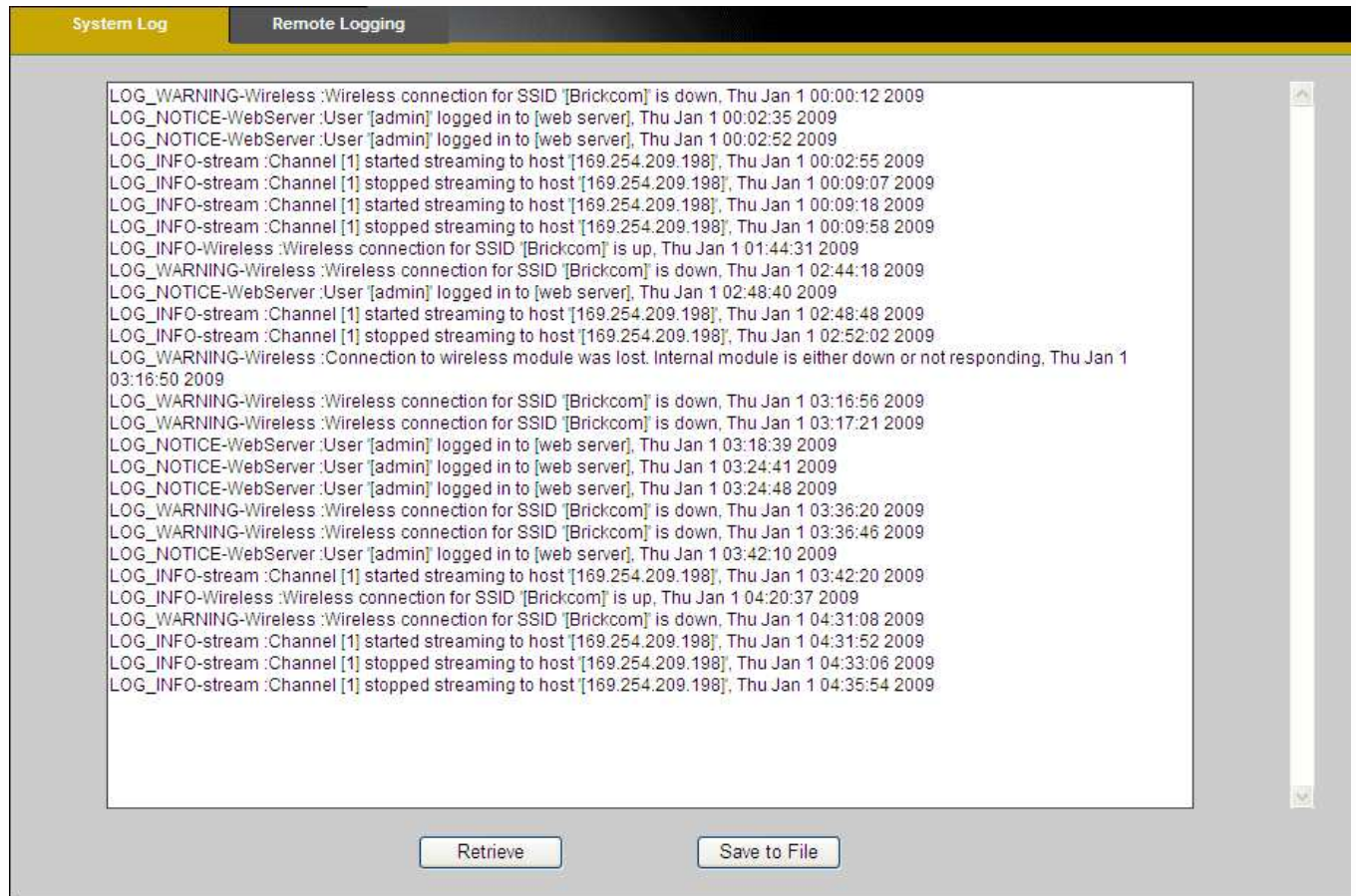

The screenshot shows a web interface with two tabs: "System Log" (selected) and "Remote Logging". Below the tabs is a large text area containing a list of log entries in chronological order. The entries include messages about wireless connections, user logins, and streaming status. At the bottom of the interface are two buttons: "Retrieve" and "Save to File".

```
LOG_WARNING-Wireless :Wireless connection for SSID [Brickcom] is down, Thu Jan 1 00:00:12 2009
LOG_NOTICE-WebServer :User [admin] logged in to [web server], Thu Jan 1 00:02:35 2009
LOG_NOTICE-WebServer :User [admin] logged in to [web server], Thu Jan 1 00:02:52 2009
LOG_INFO-stream :Channel [1] started streaming to host [169.254.209.198], Thu Jan 1 00:02:55 2009
LOG_INFO-stream :Channel [1] stopped streaming to host [169.254.209.198], Thu Jan 1 00:09:07 2009
LOG_INFO-stream :Channel [1] started streaming to host [169.254.209.198], Thu Jan 1 00:09:18 2009
LOG_INFO-stream :Channel [1] stopped streaming to host [169.254.209.198], Thu Jan 1 00:09:58 2009
LOG_INFO-Wireless :Wireless connection for SSID [Brickcom] is up, Thu Jan 1 01:44:31 2009
LOG_WARNING-Wireless :Wireless connection for SSID [Brickcom] is down, Thu Jan 1 02:44:18 2009
LOG_NOTICE-WebServer :User [admin] logged in to [web server], Thu Jan 1 02:48:40 2009
LOG_INFO-stream :Channel [1] started streaming to host [169.254.209.198], Thu Jan 1 02:48:48 2009
LOG_INFO-stream :Channel [1] stopped streaming to host [169.254.209.198], Thu Jan 1 02:52:02 2009
LOG_WARNING-Wireless :Connection to wireless module was lost. Internal module is either down or not responding, Thu Jan 1
03:16:50 2009
LOG_WARNING-Wireless :Wireless connection for SSID [Brickcom] is down, Thu Jan 1 03:16:56 2009
LOG_WARNING-Wireless :Wireless connection for SSID [Brickcom] is down, Thu Jan 1 03:17:21 2009
LOG_NOTICE-WebServer :User [admin] logged in to [web server], Thu Jan 1 03:18:39 2009
LOG_NOTICE-WebServer :User [admin] logged in to [web server], Thu Jan 1 03:24:41 2009
LOG_NOTICE-WebServer :User [admin] logged in to [web server], Thu Jan 1 03:24:48 2009
LOG_WARNING-Wireless :Wireless connection for SSID [Brickcom] is down, Thu Jan 1 03:36:20 2009
LOG_WARNING-Wireless :Wireless connection for SSID [Brickcom] is down, Thu Jan 1 03:36:46 2009
LOG_NOTICE-WebServer :User [admin] logged in to [web server], Thu Jan 1 03:42:10 2009
LOG_INFO-stream :Channel [1] started streaming to host [169.254.209.198], Thu Jan 1 03:42:20 2009
LOG_INFO-Wireless :Wireless connection for SSID [Brickcom] is up, Thu Jan 1 04:20:37 2009
LOG_WARNING-Wireless :Wireless connection for SSID [Brickcom] is down, Thu Jan 1 04:31:08 2009
LOG_INFO-stream :Channel [1] started streaming to host [169.254.209.198], Thu Jan 1 04:31:52 2009
LOG_INFO-stream :Channel [1] stopped streaming to host [169.254.209.198], Thu Jan 1 04:33:06 2009
LOG_INFO-stream :Channel [1] stopped streaming to host [169.254.209.198], Thu Jan 1 04:35:54 2009
```

This page displays the system's log in chronological order. The system log is stored in the camera's buffer area and will be overwritten when the buffer area is full.

Click **Retrieve** to retrieve the log or click **Save to file** to save the system log.



## Remote Logging

System Log	Remote Logging
Enabled	<input type="checkbox"/>
IP Address	<input type="text" value="0"/> . <input type="text" value="0"/> . <input type="text" value="0"/> . <input type="text" value="0"/> Port <input type="text" value="514"/>
<input type="button" value="Apply"/> <input type="button" value="Cancel"/>	

The user can configure the camera to send the system log file to a remote server as a log backup.

Click to enable remote log and enter the IP address of the remote server.

Enter the port number of the remote server.

Click **Apply** to apply settings or **Cancel** to cancel changes.



## Date and Time

**Manual** – Manually enter the date and time.

**Clone from PC** – The camera will sync with the time, date and time zone of the computer used to modify the camera settings. Check “Clone” to utilize this option. The read-only date and time of the PC will be displayed.

**NTP** – (Network Time Protocol) - NTP is a protocol for synchronizing the clocks of a computer system. Select to update the time with a NTP server on an hourly, daily, weekly, or monthly basis.

Time Zone – Select the local time zone from drop-down menu.

NTP Server 1 and Server 2 - Enter the address of the NTP server

Daylight Saving - Enable this option to automatically update for Daylight Savings Time.

Date and Time	
<input checked="" type="radio"/> Manual	Year <input type="text" value="2009"/> Month <input type="text" value="1"/> Day <input type="text" value="1"/> Hour <input type="text" value="0"/> Minute <input type="text" value="0"/> Second <input type="text" value="0"/>
<input type="radio"/> Clone from PC	Year <input type="text" value="2010"/> Month <input type="text" value="8"/> Day <input type="text" value="3"/> Hour <input type="text" value="17"/> Minute <input type="text" value="27"/> Second <input type="text" value="33"/> <input type="checkbox"/> Clone
<input type="radio"/> NTP	TimeZone: <input type="text" value="(GMT+8)HONG KONG"/> <input type="button" value="v"/> NTP Server 1: <input type="text" value="tick.stdtime.gov.tw"/> NTP Server 2: <input type="text" value="clock.stdtime.gov.tw"/> Daylight Saving: <input type="checkbox"/> Enabled

Click **Apply** to apply settings or **Cancel** to cancel changes.

## Device Information

**System Information** – Displays the complete system information of the camera.

System Information	Network Settings	Video/Audio Settings
LAN MAC Address	00:26:82:59:2C:11	
Wireless MAC Address	00:26:82:59:2C:12	
Firmware Version	v3.0.6.5	
Product Name	WCB-100Ap	
Hardware Version	V1	
Company Name	Brickcom Corporation	
UPnP Name	WCB-100Ap-2c11	

**Network Settings** – Displays the complete network settings information of the camera.

System Information	Network Settings	Video/Audio Settings
IP Setting Type	Static	
IP Address	169.254.209.208	
Subnet Mask	255.255.0.0	
Default Gateway	169.254.209.198	
Primary DNS	0.0.0.0	
Secondary DNS	0.0.0.0	
UPnP	Enabled	
DynDNS	Disabled	
TZO	Disabled	

**Video/Audio Settings** – Displays the complete video/audio settings information of the camera.

System Information	Network Settings	Video/Audio Settings
<b>Stream 1</b>		
Video Codec	H.264	
Video Resolution	1280x800(WXGA)	
Video Frame Rate	25 fps	
Video Bitrate	1500 Kbps	
Audio Codec	N/A	
Multicast IP	N/A	
<b>Stream 2</b>		
Video Codec	MJPEG	
Video Resolution	1280x800(WXGA)	
Video Frame Rate	25 fps	
Video Quality	3	
Audio Codec	N/A	
Multicast IP	N/A	

## Storage Management(\*)

Storage Management is used to view all the recorded files on the Micro-SD/SDHC card.

Click **Reload** to refresh the list of recorded files.

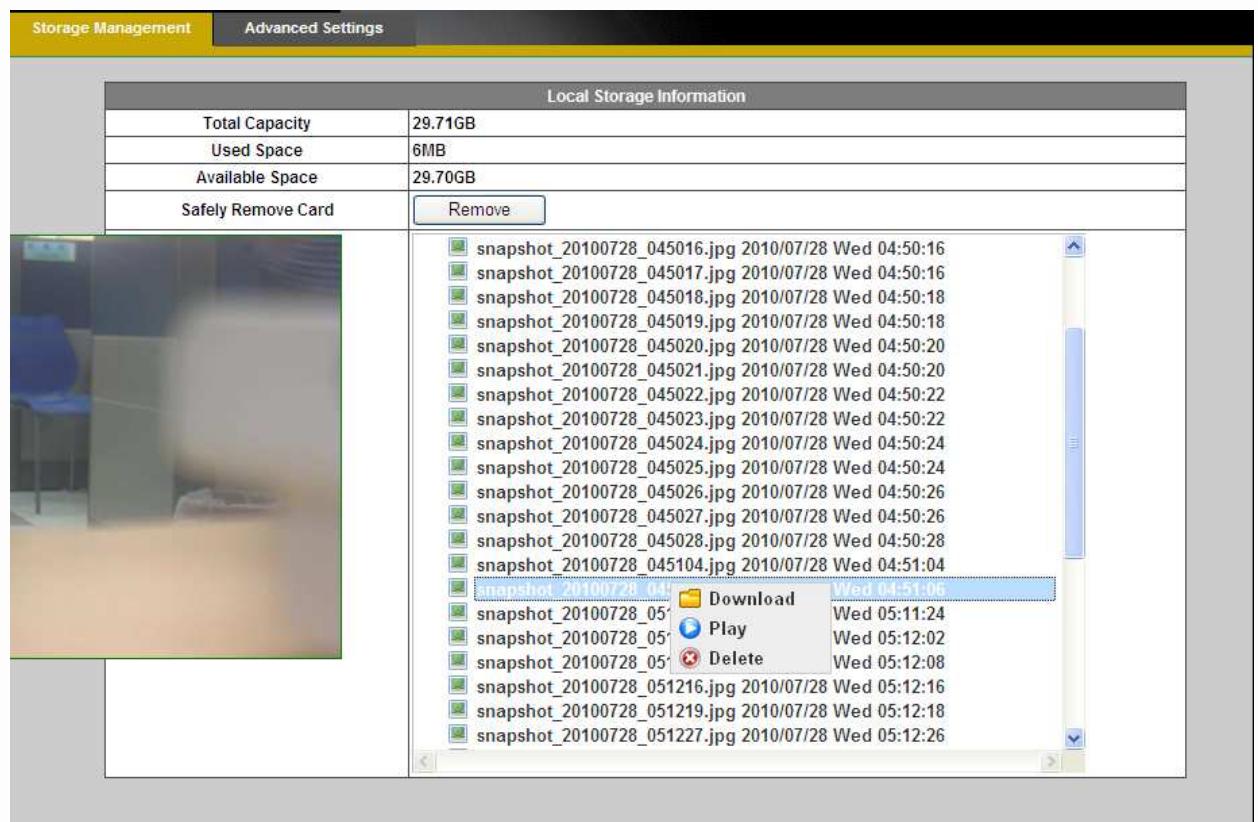
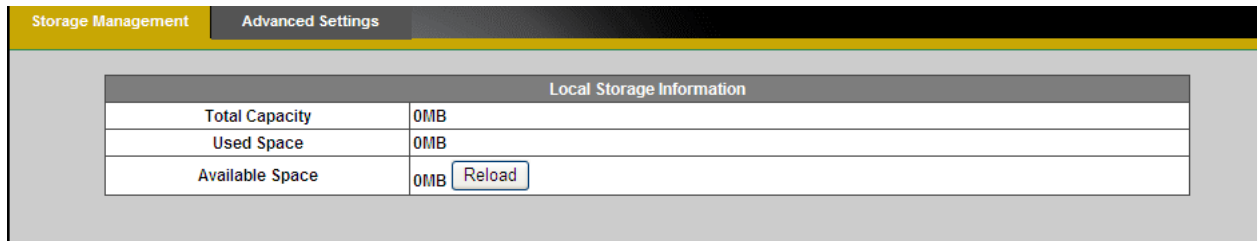

Click **Remove** to safely remove the SD/SDHC memory card.

Left click on the folder to list the recorded files. The user can either play the snapshot of the recorded files by moving the mouse pointer over the file or double click on a file to play it.

Right click on the folder to download, play or delete the recorded files.



**NOTE** – The user may need to install QuickTime multimedia framework to play the video clips.

## Advanced Settings

Storage Management    **Advanced Settings**

**Automatic Recycle**

Enabled

**Offline Record**

Enabled

If the Automatic Recycle function is disabled, there must be at least 50MB Hard Drive space available for the network camera to record video.

If the Automatic Recycle function is enabled, it will automatically overwrite the recorded files when the available space remaining is less than 100MB.

Apply    Cancel

**Automatic Recycle(\*)** – Enable to automatically overwrite older files when the available space remaining on the Micro-SD/SDHC card is less than 100MB. If the Automatic Recycle function is disabled, there must be at least 50MB hard drive space available for the camera to be able to record video files.

**Offline Record** – Enable to keep recording if the Network Camera is offline.

Click **Apply** to apply settings or **Cancel** to cancel changes.

## LED Indicators

The LED on the front of the camera can be configured to remain unlit. Check “OFF” to enable this function.

**LED Indicators**

**LED Indicators Configuration**

OFF

Apply    Cancel

Click **Apply** to apply settings or **Cancel** to cancel changes.

## Maintenance

### User Management

This section explains how to enable password protection and create multiple accounts.

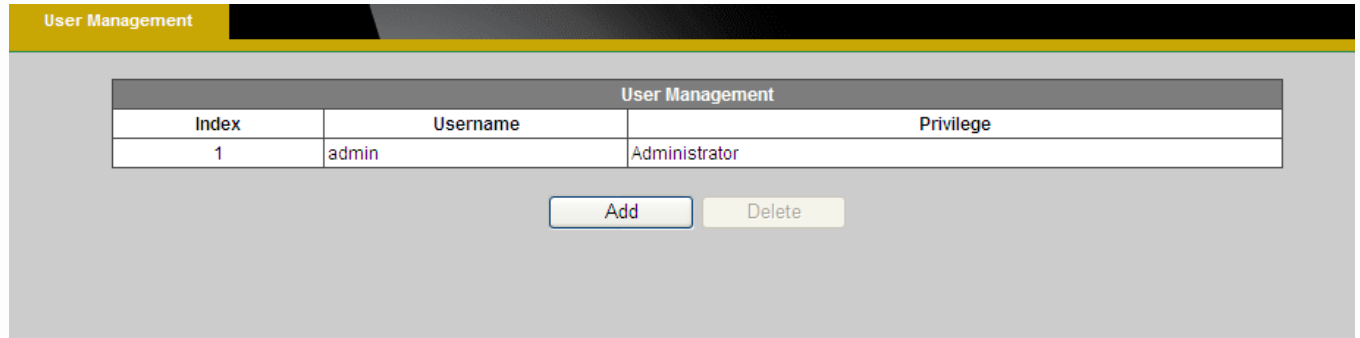

The administrator account name is “admin”, which is permanent and cannot be deleted.

Click **Add** to create an account.

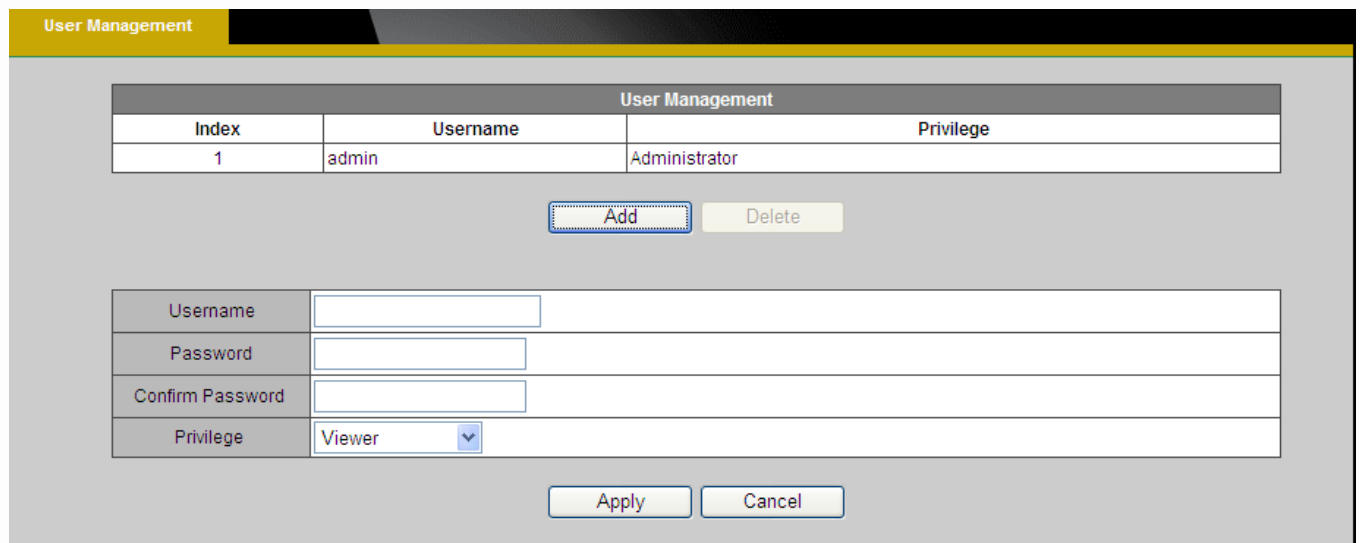

Enter the new user’s name, password and confirm password. Administrators can add up to 10 user accounts.

Select the privilege level for the new user account from the drop-down list. Privilege levels can be assigned as:

- ◆ Administrator - user has access to view and change the Configuration page. Users with administrator privilege can change other user's access rights and delete user accounts. Click **Delete** or **Update** to delete or modify a user's account.
- ◆ Viewer - user can only access the main page for live viewing.
- ◆ Remote Viewer - user can only access the main page for live viewing using TCP protocol.

## Language

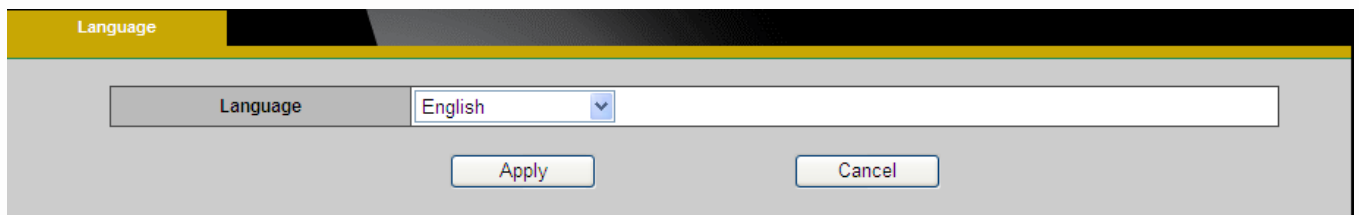

The screenshot shows a configuration window titled "Language". It features a dropdown menu currently set to "English". Below the dropdown are two buttons: "Apply" and "Cancel".

Select the desired language from the drop-down menu.

Click **Apply** to apply settings or **Cancel** to cancel changes.

## IP Filter

The IP Filter is used to filter the IP addresses which are able to access the network camera.

Enable the IP Filter and select to allow or deny a range of IP addresses access to the server.

Click **Add to list** to add the IP range to the IP filter list.

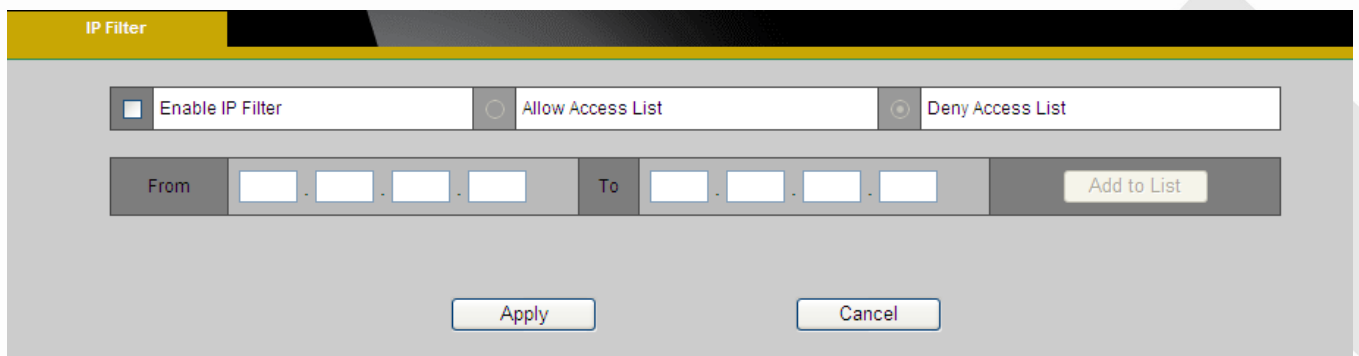

The screenshot shows a configuration window titled "IP Filter". It has three radio buttons: "Enable IP Filter" (checked), "Allow Access List", and "Deny Access List". Below these are two IP address input fields labeled "From" and "To", and an "Add to List" button. At the bottom are "Apply" and "Cancel" buttons.

Click **Apply** to apply settings or **Cancel** to cancel changes.

## Firmware Upgrade

This feature allows the user to upgrade the camera firmware. It will take a few minutes to complete the process.



**NOTE** - Do not power off the camera or camera during the upgrade.

**Upgrade** - Click **Browse...** and specify the firmware file. Click **Upgrade**. The camera will begin upgrading and will reboot automatically when the upgrade is finished.

Firmware Upgrade			
Select a File	<input type="text"/>	Browse...	Upgrade

## Configuration

This feature allows the user to export/import the configuration files of the network camera.

**Import/Export** - Click **export** to pop up a dialog to indicate the location and file to export. Click **browse** to indicate the location and file of the camera configuration and click **import** to import the configuration file back into the network camera.

Import / Export	
Export	<input type="button" value="Export"/>
Import	Please select a file to import <input type="text"/>
	<input type="button" value="Browse..."/>
	<input type="button" value="Import"/>



## Reset to Default

Click **Apply** to restore the network camera to factory default setting.

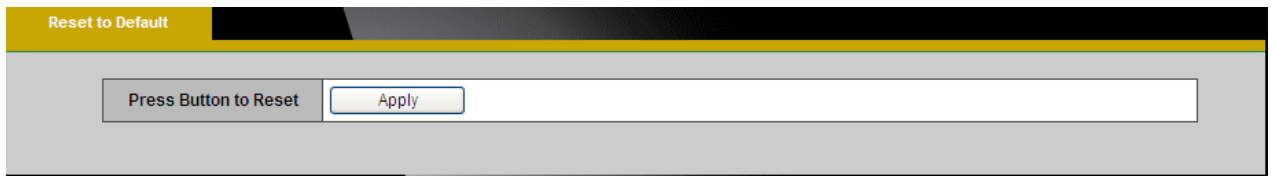

## Reboot

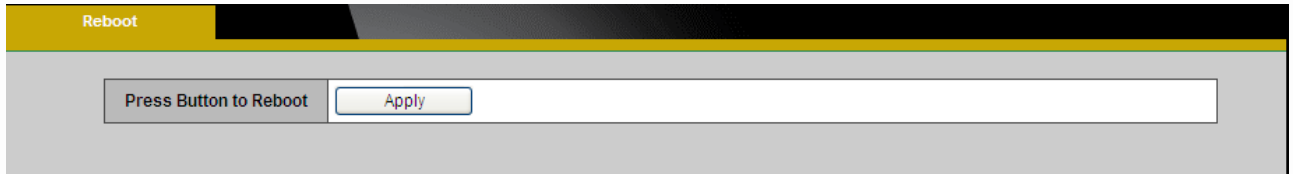

This feature will reboot the camera. Click **Apply** to begin. A message will pop up asking “The device will reboot. Are you sure?” Click “OK” to continue. The camera will take about one minute to reboot.



The following message will show during the rebooting process.

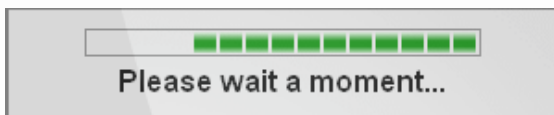

When completed, the live video page will be displayed in the web browser.