

Brickcom

Hardware User's Manual

Megapixel Day & Night
Outdoor Bullet Network Camera
Quality Service Group
Outdoor Bullet V2 Series

Review History:

1. Separate User Manual into HW and SW.
2. Merge OB-100A V2 series /OB-130N-series into this User Manual.

Product name: Network Camera (Outdoor Bullet V2 series)

Release Date: 2011/09

Manual Revision: V3.0

Web site: www.brickcom.com

Email: technical@brickcom.com

info@brickcom.com

© 2011 Brickcom Corporation. All Rights Reserved

Table of Contents

| | |
|---|----|
| Before You Use This Product | 1 |
| Regulatory Information | 2 |
| Plaque signalétique du produit final..... | 4 |
| Chapter 1 - Package Contents..... | 6 |
| Chapter 2 - Outdoor Bullet Network Camera Overview..... | 8 |
| Chapter 3 - Device Appearance Description | 9 |
| Chapter 4 - Installation | 13 |
| 4.1 Hardware Installation..... | 13 |
| 4.2 Camera Connection..... | 19 |
| 4.3 System Requirements | 21 |
| 4.4 Software Installation..... | 22 |
| 4.3.1 EasyConfig..... | 30 |



Before You Use This Product

In many countries, there are laws prohibiting or restricting the use of surveillance devices. This Network Camera is a high-performance, web-ready camera which can be part of a flexible surveillance system. It is the user's responsibility to ensure that the operation of this camera is legal before installing this unit for its intended use.

Upon opening the product's package, verify that all the accessories listed on the "Package Contents" are included. Before installing the Network Camera, read the warnings in the "Quick Installation Guide" to avoid misuse. When installing the Network Camera, carefully read and follow the instructions in the "Installation" chapters to avoid damages due to faulty assembly or installation.

Regulatory Information

Federal Communication Commission Interference Statement

This equipment has been tested and found to comply with the limits for a Class B digital device, pursuant to Part 15 of the FCC Rules. These limits are designed to provide reasonable protection against harmful interference in a residential installation. This equipment generates uses and can radiate radio frequency energy and, if not installed and used in accordance with the instructions, may cause harmful interference to radio communications. However, there is no guarantee that interference will not occur in a particular installation. If this equipment does cause harmful interference to radio or television reception, which can be determined by turning the equipment off and on, the user is encouraged to try to correct the interference by one of the following measures:

- Reorient or relocate the receiving antenna.
- Increase the separation between the equipment and receiver.
- Connect the equipment into an outlet on a circuit different from that to which the receiver is connected.
- Consult the dealer or an experienced radio/TV technician for help.

FCC Caution: Any changes or modifications not expressly approved by the party responsible for compliance could void the user's authority to operate this equipment.

This device complies with Part 15 of the FCC Rules. Operation is subject to the following two conditions: (1) This device may not cause harmful interference, and (2) this device must accept any interference received, including interference that may cause undesired operation.



IMPORTANT NOTE:

FCC Radiation Exposure Statement:

This equipment complies with FCC radiation exposure limits set forth for an uncontrolled environment. This equipment should be installed and operated with minimum distance 20cm between the radiator & your body.

This transmitter must not be co-located or operating in conjunction with any other antenna or transmitter.

The availability of some specific channels and/or operational frequency bands are country dependent and are firmware programmed at the factory to match the intended destination. The firmware setting is not accessible by the end user.

Industry Canada statement:

Ce dispositif est conforme à la norme CNR-210 d'Industrie Canada applicable aux appareils radio exempts de licence. Son fonctionnement est sujet aux deux conditions suivantes: (1) le dispositif ne doit pas produire de brouillage préjudiciable, et (2) ce dispositif doit accepter tout brouillage reçu, y compris un brouillage susceptible de provoquer un fonctionnement indésirable.

NOTE IMPORTANTE: (Pour l'utilisation de dispositifs mobiles)

Déclaration d'exposition aux radiations:

Cet équipement est conforme aux limites d'exposition aux rayonnements IC établies pour un environnement non contrôlé. Cet équipement doit être installé et utilisé avec un minimum de 20 cm de distance entre la source de rayonnement et votre corps.

Avertissement:

Le dispositif fonctionnant dans la bande 5150-5250 MHz est réservé uniquement pour une utilisation à l'intérieur afin de réduire les risques de brouillage préjudiciable aux systèmes de satellites mobiles utilisant les mêmes canaux.

Les utilisateurs de radars de haute puissance sont désignés utilisateurs principaux (c.-à-d., qu'ils ont la priorité) pour les bandes 5250-5350 MHz et 5650-5850 MHz et que ces radars pourraient causer du brouillage et/ou des dommages aux dispositifs LAN-EL.

Conformément à la réglementation d'Industrie Canada, le présent émetteur radio peut fonctionner avec une antenne d'un type et d'un gain maximal (ou inférieur) approuvé pour l'émetteur par Industrie Canada. Dans le but de réduire les risques de brouillage radioélectrique à l'intention des autres utilisateurs, il faut choisir le type d'antenne et son gain de sorte que la puissance isotrope rayonnée équivalente (p.i.r.e.) ne dépasse pas l'intensité nécessaire à l'établissement d'une communication satisfaisante.

Le présent émetteur radio (IC: 9219A-WMDR129N) a été approuvé par Industrie Canada pour fonctionner avec les types d'antenne énumérés ci-dessous et ayant un gain admissible maximal et l'impédance requise pour chaque type d'antenne. Les types d'antenne non inclus dans cette liste, ou dont le gain est supérieur au gain maximal indiqué, sont strictement interdits pour l'exploitation de l'émetteur.

Ce dispositif a été conçu pour fonctionner avec une antenne ayant un gain maximal de dB [2.02]. Une antenne à gain plus élevée est strictement interdite par les règlements d'Industrie Canada. L'impédance d'antenne requise est de 50 ohms.

Cet appareil est conçu uniquement pour les intégrateurs OEM dans les conditions suivantes:
(Pour utilisation de dispositif module)

- 1) L'antenne doit être installée de telle sorte qu'une distance de 20 cm est respectée entre l'antenne et les utilisateurs, et
- 2) Le module émetteur peut ne pas être coïmplanté avec un autre émetteur ou antenne,
- 3) Pour tous les produits vendus au Canada, OEM doit limiter les fréquences de fonctionnement CH1 à CH11 pour bandes de fréquences 2.4G grâce aux outils de microprogrammation fournis. OEM ne doit pas fournir d'outil ou d'informations à l'utilisateur final en ce qui concerne le changement de réglementation de domaine.

Tant que les 3 conditions ci-dessus sont remplies, des essais supplémentaires sur l'émetteur ne seront pas nécessaires. Toutefois, l'intégrateur OEM est toujours responsable des essais sur son produit final pour toutes exigences de conformité supplémentaires requis pour ce module installé.

NOTE IMPORTANTE:

Dans le cas où ces conditions ne peuvent être satisfaites (par exemple pour certaines configurations d'ordinateur portable ou de certaines co-localisation avec un autre émetteur), l'autorisation du Canada n'est plus considérée comme valide et l'ID IC ne peut pas être utilisé sur le produit final. Dans ces circonstances, l'intégrateur OEM sera chargé de réévaluer le produit final (y compris l'émetteur) et l'obtention d'une autorisation distincte au Canada.

Plaque signalétique du produit final

Ce module émetteur est autorisé uniquement pour une utilisation dans un dispositif où l'antenne peut être installée de telle sorte qu'une distance de 20cm peut être maintenue entre l'antenne et les utilisateurs. Le produit final doit être étiqueté dans un endroit visible avec l'inscription suivante: "Contient des IC: 9219A-WMDR129N.

Manuel d'information à l'utilisateur final







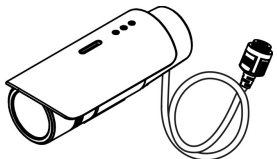

L'intégrateur OEM doit être conscient de ne pas fournir des informations à l'utilisateur final quant à la façon d'installer ou de supprimer ce module RF dans le manuel de l'utilisateur du produit final qui intègre ce module.

Le manuel de l'utilisateur final doit inclure toutes les informations réglementaires requises et avertissements comme indiqué dans ce manuel.

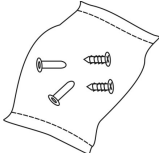
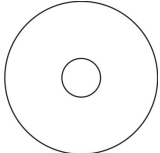
Chapter 1 - Package Contents

Please check to make sure the product package contains all the accessories listed below.

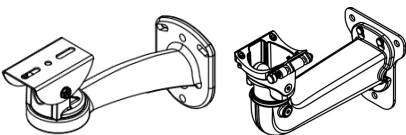
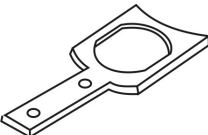
A. Camera Package Contents

| | |
|---|--|
| <p>a. Network Camera (Outdoor Bullet V2 Series)</p>  | <p>b. Shielding Cover</p>  |
| <p>c. Screw bag</p>  | <p>d. Product CD</p>  |
| <p>e. Warranty Card / Easy Installation Guide</p>  | <p>f. 2 Water Proof Connectors</p>  |
| <p>g. Dry Bag</p>  | <p>h. High Power POE (Optional)</p>  |
| <p>i. Bracket (Optional)</p>  | <p>j. Bracket Assembly Plate (Optional)</p>  |
| <p>k. Wi-Fi Dual Band Antenna package (Optional)</p>  | <p>l. 3G Antenna package (Optional)</p>  |

B. Wi-Fi Antenna Package contents (Optional)

Refer to the installation guide included in the package when installing the Wi-Fi antenna

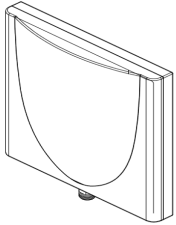
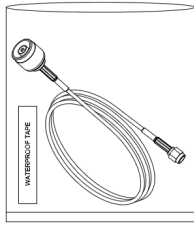
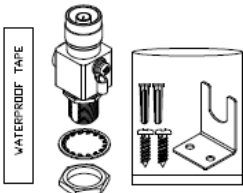
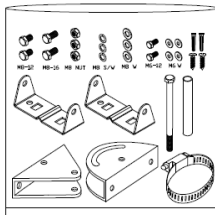
| | |
|--|--|
| <p>a. Wi-Fi Dual Band Antenna</p>  | <p>b. Extension Cable</p>  |
| <p>c. Surge Arrestor Kit</p>  | <p>d. Mount Kit</p>  |

C. Wi-Fi Antenna Package contents (Optional)

Refer to the installation guide included in the package when installing the 3G antenna

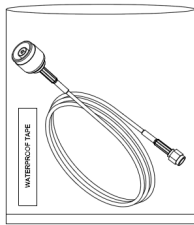
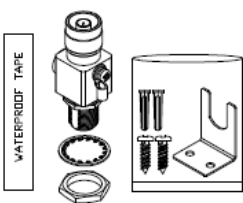
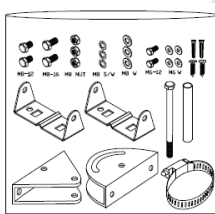
| | |
|---|--|
| <p>a. 3G Antenna</p>  | <p>b. Extension Cable</p>  |
| <p>c. Surge Arrestor Kit</p>  | <p>d. Mount Kit</p>  |

Chapter 2 - Outdoor Bullet Network Camera Overview

The Brickcom Outdoor Bullet SERIES is an outdoor bullet network camera. It adopts a megapixel sensor which allows the camera to deliver extremely clear and detailed images that CCTV cameras cannot offer. To optimize use of the megapixel resolution, the Outdoor Bullet SERIES uses efficient H.264/ MJPEG/ MPEG-4 codec compression to deliver dual configurable video streams simultaneously at up to 30 fps. These features make this series the perfect outdoor camera for neighborhood, school campus, and parking lot surveillance.

The Outdoor Bullet SERIES has many user friendly features, such as the Smart Focus capability which allows users to configure settings for excellent image quality without difficult procedures. Support for Power over Ethernet enables the camera to use the same cable for power and data transmission, eliminating the need to install an external power supply.

Installation for the WOB/GOB Series models is not restricted by location or landforms. The cameras offer various wireless options that make connecting to networks easier by adopting the technology of IEEE 802.11 a/b/g/n and 3G SIM module. The wireless Bullet Cameras can be set within any wireless or 3G signal coverage areas. Users do not have to worry about the data connection failing because each camera is equipped with a SD/SDHC memory card slot for local storage.

With an IP67 certified outdoor enclosure, the Outdoor Bullet SERIES is not only weather proof, but also dust and rust resistant. By utilizing a built-in industrial fan and heater, it can perform well in extreme environments.

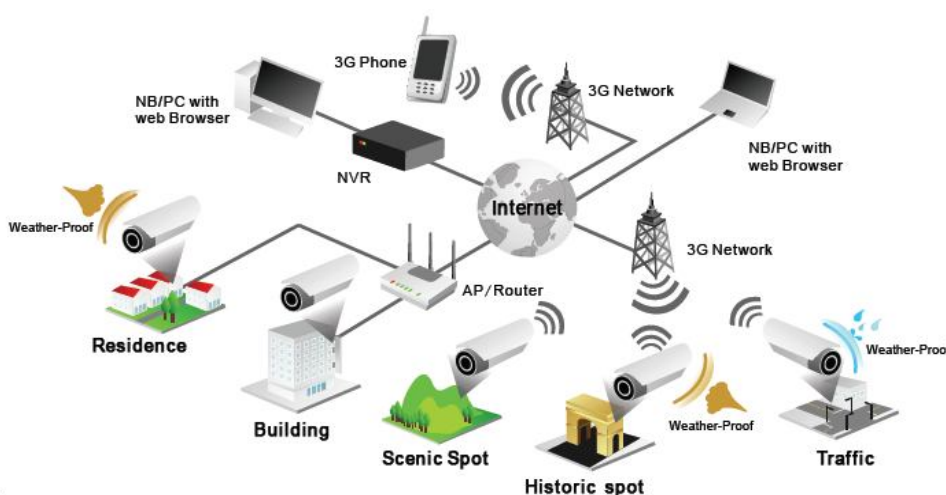

Chapter 3 - Device Appearance Description

< Front Panel >

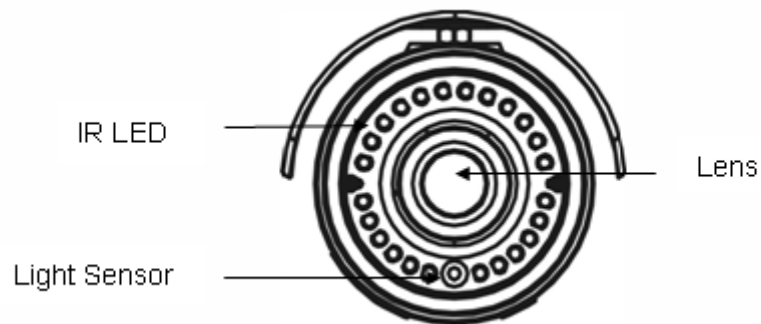

< Rear Panel >

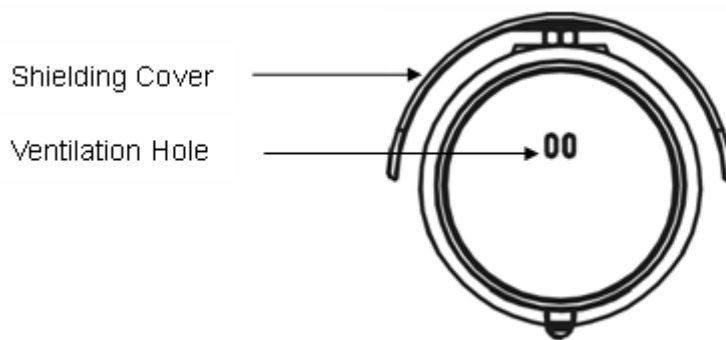

< Top >

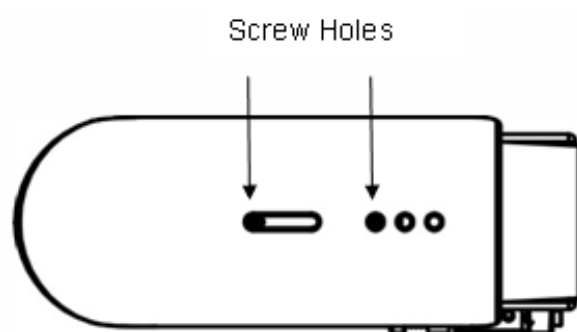

< Bottom >

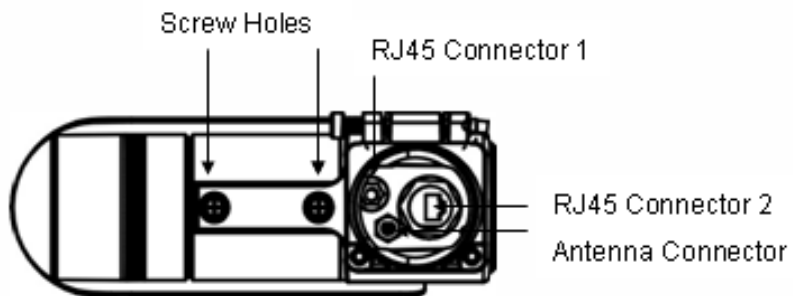

< Side >

Micro-SD/SDHC Card Slot

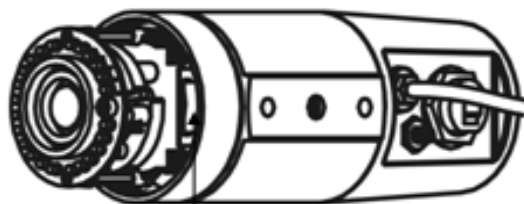
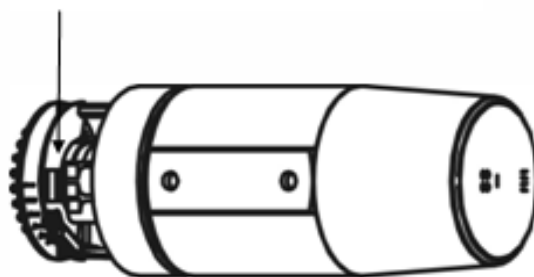

3G SIM Card Slot

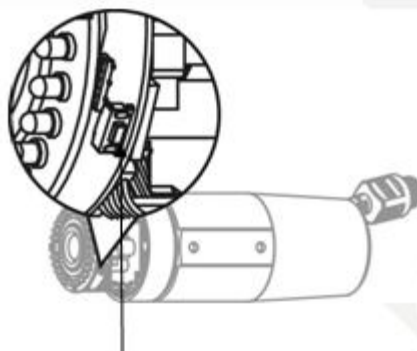

Reset Button

< Extension I/O Terminal Block >

The Network Camera provides an extension I/O terminal block which is used to connect the camera with external input/output devices. The pin definitions are listed as below.

| Pin | Function |
|-----|----------------|
| 1 | Power + 4.5V |
| 2 | Digital Output |
| 3 | Digital Input |
| 4 | Ground |

| Pin | Function |
|-----|----------|
| 1 | RS485+ |
| 2 | RS485- |
| 3 | AC24V |
| 4 | AC24V |

< DI/DO Diagram >

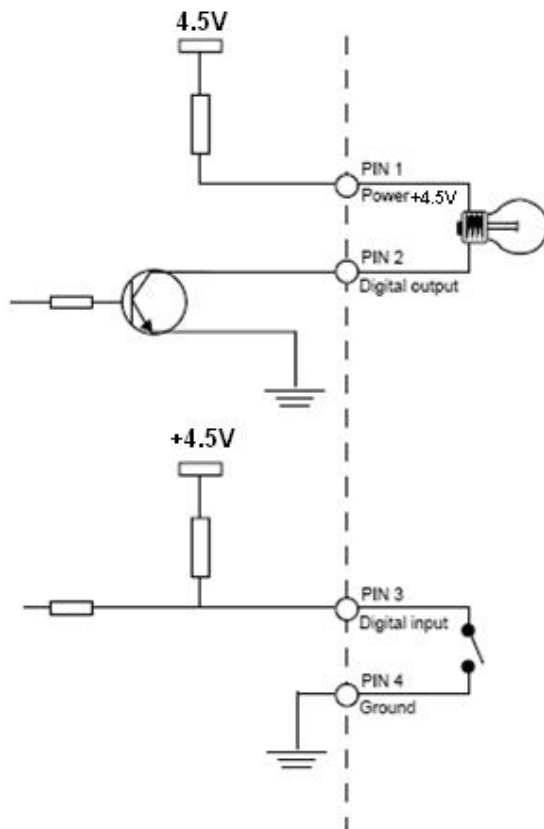

< Hardware Reset >

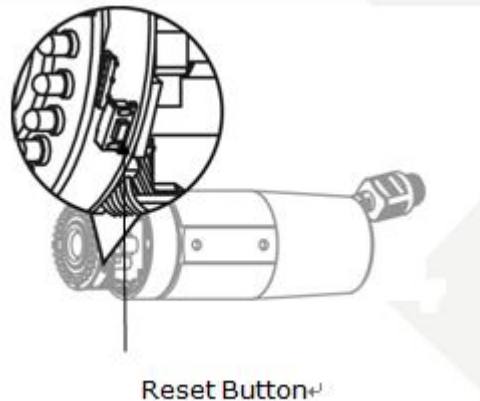

The Reset Button can be used to reboot the camera or restore it to factory default settings. If the camera experiences a problem, rebooting the camera may correct the problem. If the problem remains, please restore the camera to factory default settings and reinstall the software.

To Reboot

Press and hold the Reset Button for one second using a paper clip or thin object. Wait for the camera to reboot.

To Restore

Press and hold the Reset Button for ten seconds until the LED light turns off. When successful restored, the LED will be blue during normal operation.



NOTE - By restoring the camera, all settings will be restored to the factory default settings.

Micro-SD/SDHC Card Capacity

The network camera is compatible with Micro-SD/SDHC (Maximum 32GB) cards.

(* These are optional features. Please refer to the Product List for the full list of optional features that are available for this product.

Chapter 4 - Installation

4.1 Hardware Installation

 **WARNING** - Do not mount the camera on a soft material. The camera may fall and be damaged.

A. Micro-SD/SDHC Card and 3G SIM Card Installation

- a. Remove the Lens cover from the Bullet Camera.

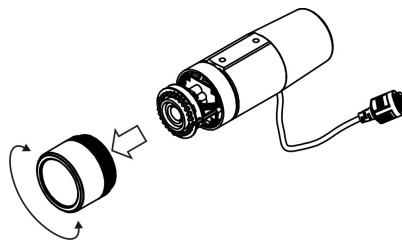

- b. Inset the Micro SD/SDHC card and 3G SIM card(*) into their respective slots.

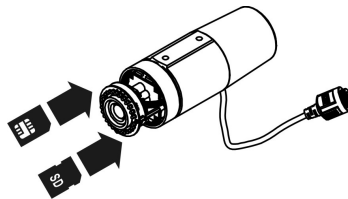

- c. Place a dry bag onto the camera device.

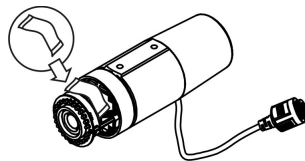

- d. Reattach the Lens cover and secure the cover to the top of the camera device using two screws.

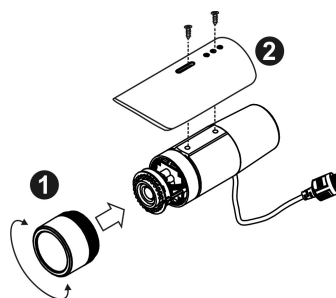

B. Wall Installation Using the Optional Bracket

- a. Using the Bracket plate as a guide, drill three holes into the wall and hammer the supplied plastic anchors into the three holes. Use a screwdriver and the supplied screws to secure the plate to the wall.

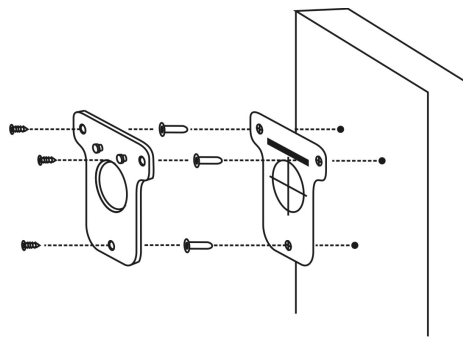

- b. Attach the Bracket Assembly Plate to the bottom of the camera using two screws.

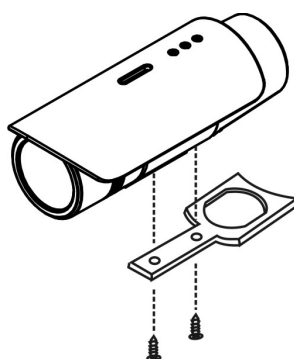

- c. (1) Use the two supplied screws to secure the bracket to the side of the camera. (2) Push back the spring on the mortise lock and hook the camera and attached bracket onto the groove of the wall mount bracket as shown in the diagram.

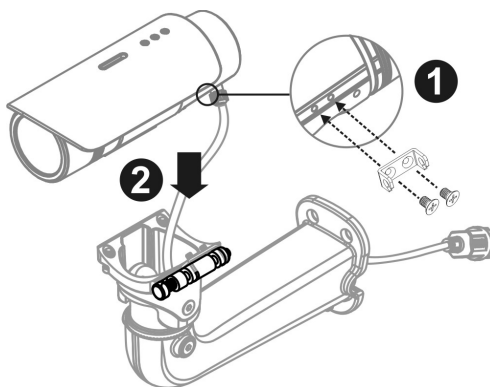

- d. Connect (1) the POE cable; (2) DIDO, Audio In/Out, RS485 cable; and (3) Antenna cable with the camera. Refer to step 3 for more details installation information.

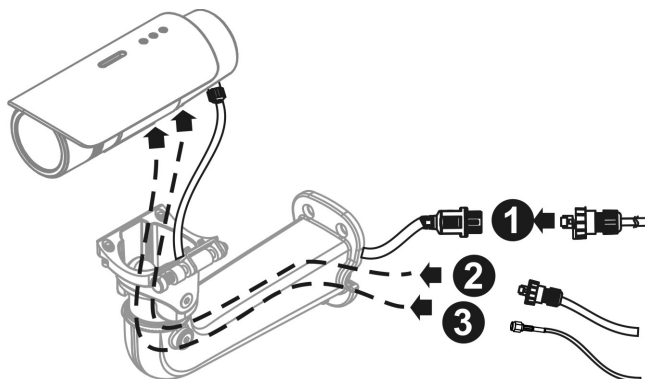

- e. Secure the two screws on the wall mount bracket.

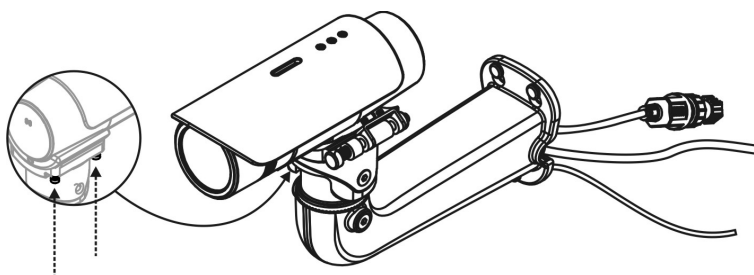

- f. Place the wall mount bracket on the plate and attach it using the supplied screws. Adjust the angle of the wall mount bracket towards the area to be monitored.

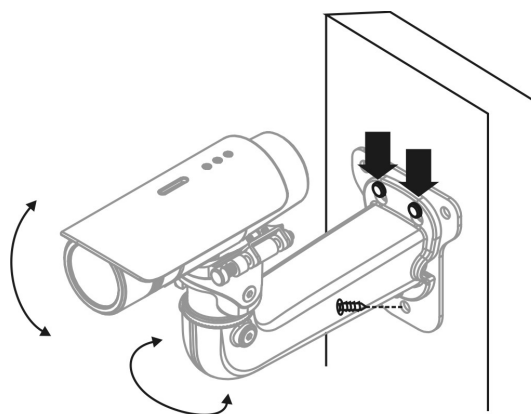

C. DIDO, Audio In/Out, RS485, and Antenna Connection

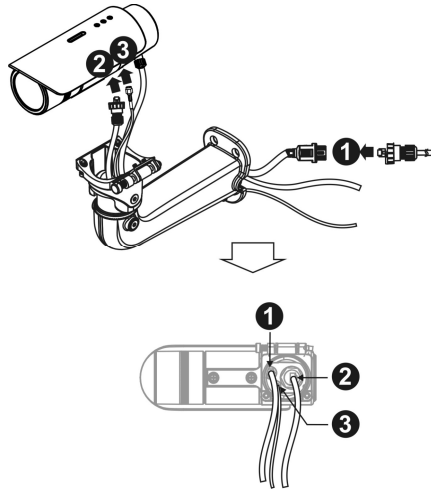

a. PoE Connection

For the Power over Ethernet connection, construct the PoE cable using the pin definitions of the RJ45 connector below and refer to step 5 for instructions on how to install the Water Proof Connector. Once the PoE cable has been constructed using the waterproof connector, pass the RJ-45 cable from the camera through the bracket and connect it to the PoE cable.



| RJ45 Connector 1 | |
|------------------|---------------------|
| Pin No. | Function |
| Pin 1 | Transmit Out+ (Tx+) |
| Pin 2 | Transmit Out- (Tx-) |
| Pin 3 | Receive In+ (Rx+) |
| Pin 4 | DC 48V |
| Pin 5 | DC 48V |
| Pin 6 | Receive In- (Rx-) |
| Pin 7 | 48V_GND |
| Pin 8 | 48V_GND |

b. DIDO, Audio In/Out, RS485 Cable Connection

For the DIDO, Audio In/Out and RS485 cable connection, construct an Ethernet cable using the pin definitions of the RJ-45 connector below and refer to step 4 for instructions on how to install the Water Proof Connector. Once the Ethernet cable has been constructed using the waterproof connector, pass the cable through the bracket and connect it to the RJ-45 connector at the bottom of the camera.



| RJ45 Connector 2 | |
|------------------|----------------|
| Pin No. | Function |
| Pin 1 | Power +4.5V |
| Pin 2 | Digital Output |
| Pin 3 | Digital Input |
| Pin 4 | Ground |
| Pin 5 | RS-485- |
| Pin 6 | RS-485+ |
| Pin 7 | Audio-in |
| Pin 8 | Audio-out |

DIDO Diagram

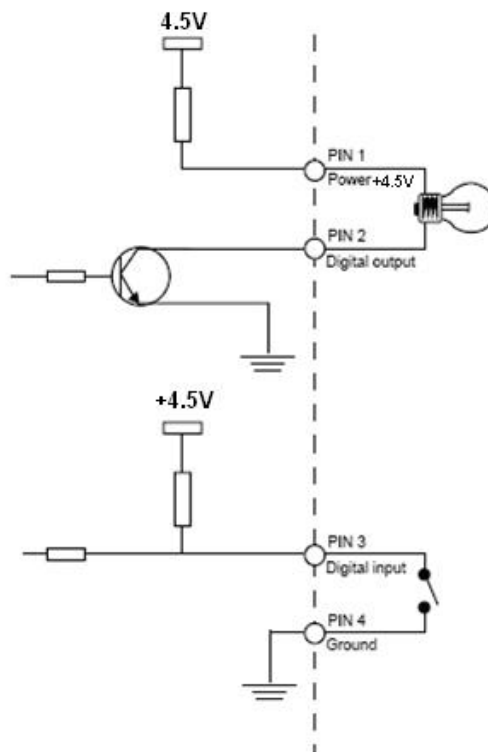

c. WiFi or 3G Antenna Extension Cable Connection

Pass the Antenna extension cable (1) through and bracket and connect it to the Antenna connector (2) at the bottom of the camera.

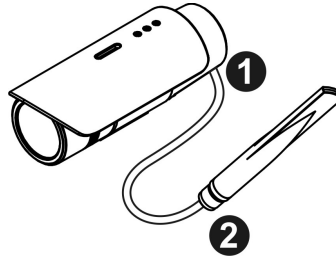

d. Water Proof Connector

Refer to the installation guide included in the package when installing the Water Proof connector.

- i. Insert the stripped cable through the sealing nut and the housing. Clamp the cable with an RJ45 plug.
- ii. Push the RJ45 plug into the housing and secure the sealing nut tightly.
- iii. Attach the gasket to the front of the housing.
- iv. Connect the Ethernet cable to the RJ45 cable.
- v. Secure the connectors tightly.

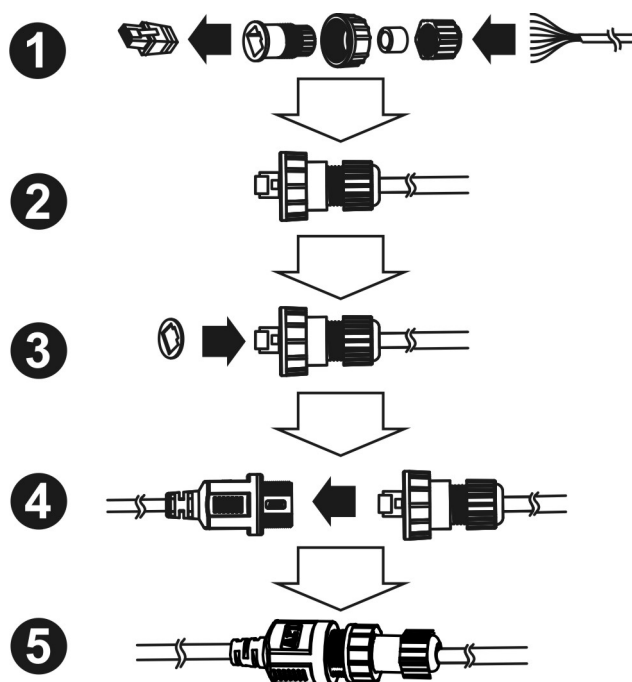

4.2 Camera Connection

The Outdoor Bullet Series is PoE compliant, so there are two options for connecting the camera to a power and Ethernet source. The camera can either be connected to a PoE-enabled switch or a non-PoE switch.

a. If using a PoE-enabled switch:

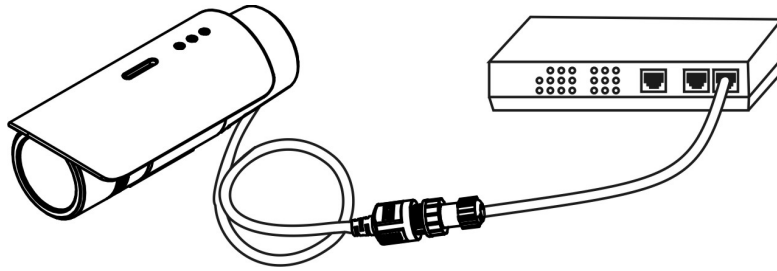

- i. Use a single Ethernet cable to connect the camera to the PoE-enabled switch.

b. If using a non-PoE switch:

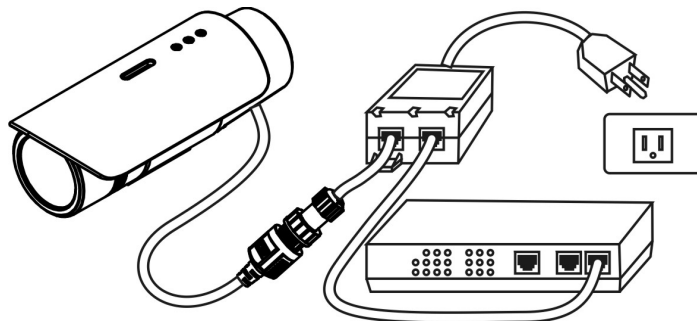

- i. Use a standard RJ-45 cable to connect the camera to a PoE Injector.
- ii. Use a standard RJ-45 cable to connect the PoE Injector to the non-PoE switch.
- iii. Use a standard power cable to connect the PoE Injector to a power outlet.

c. If using a PoE injector as power input (For GOB/WOB Series):

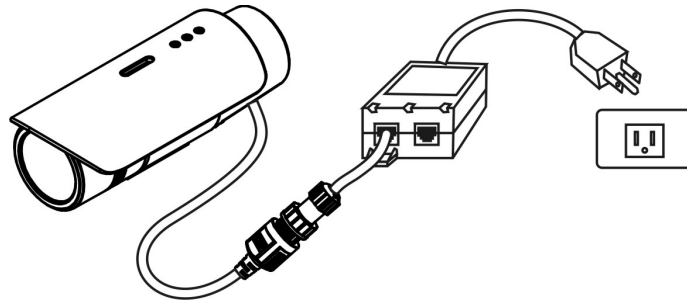

- i. Use a standard RJ-45 cable to connect the camera to a PoE Injector.
- ii. Use a standard power cable to connect the PoE Injector to a power outlet.

4.3 System Requirements

Operating System:

Microsoft Windows XP Home Edition SP2

Microsoft Windows XP Professional SP2

Computer:

IBM PC/AT Compatible

CPU:

Pentium 3GHz or faster

Memory:

1024 MB or more

Monitor:

1024 x 768 pixels or more, 24-bit True color or better

Network Interface:

10/100Mbps Network interface card must be installed

Web Browser:

Microsoft Internet Explorer 6.0 SP2 or higher

Adobe Reader:

Adobe Reader 8.0 or higher

Audio:

The audio function will not work if a sound card is not installed in the PC. Audio may be interrupted depending on network traffic.

4.4 Software Installation

In this manual, "User" refers to whoever has access to the Network Camera, and "Administrator" refers to the person who can configure the camera and grant user access to the camera.

After checking the hardware connection, run the Installation Wizard program included on the product's CDROM to automatically search the intranet for the camera. There may be many cameras on the local network. Differentiate the cameras using the serial number which is printed on the labels on the carton and the bottom of the camera.

- A. Insert the Installation CD into the CD-ROM driver. Run Auto-Run Tool directly from the CD-ROM to start the installation. When installing the Brickcom software kit for the first time, select a desired language for the interface. The available languages are listed in the scroll box. Click **<Install>** and follow the steps to install the EasyConfig wizard on the desired computer.



B. In the Install Shield Wizard dialog box, click <Next> to continue.

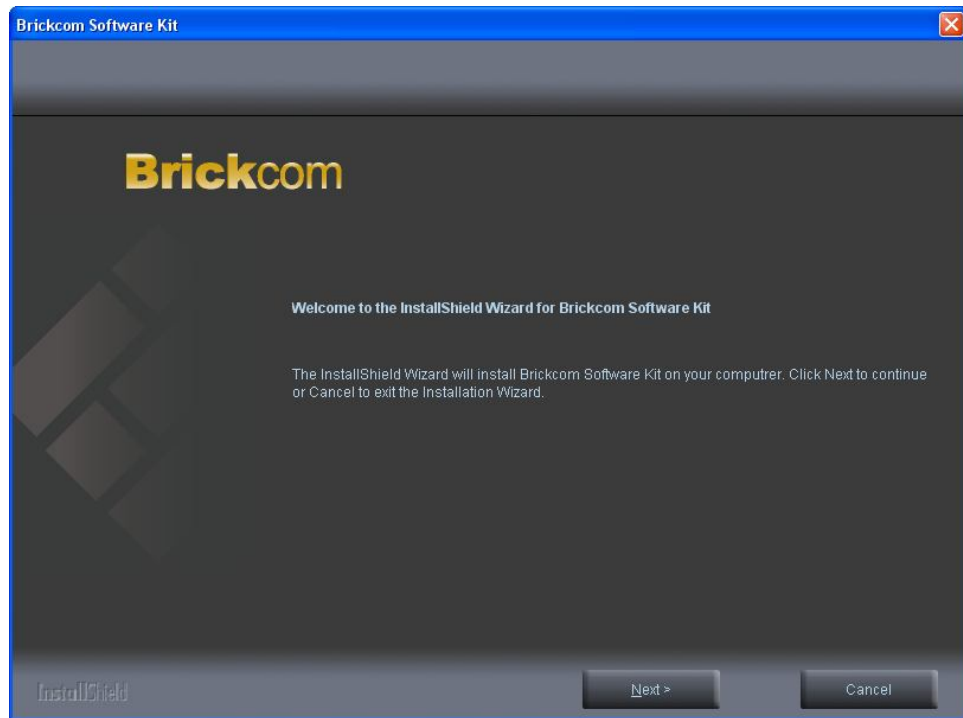

C. Read the End-User License Agreement and check the option "I accept the terms of the license agreement". Click <Next> to continue.

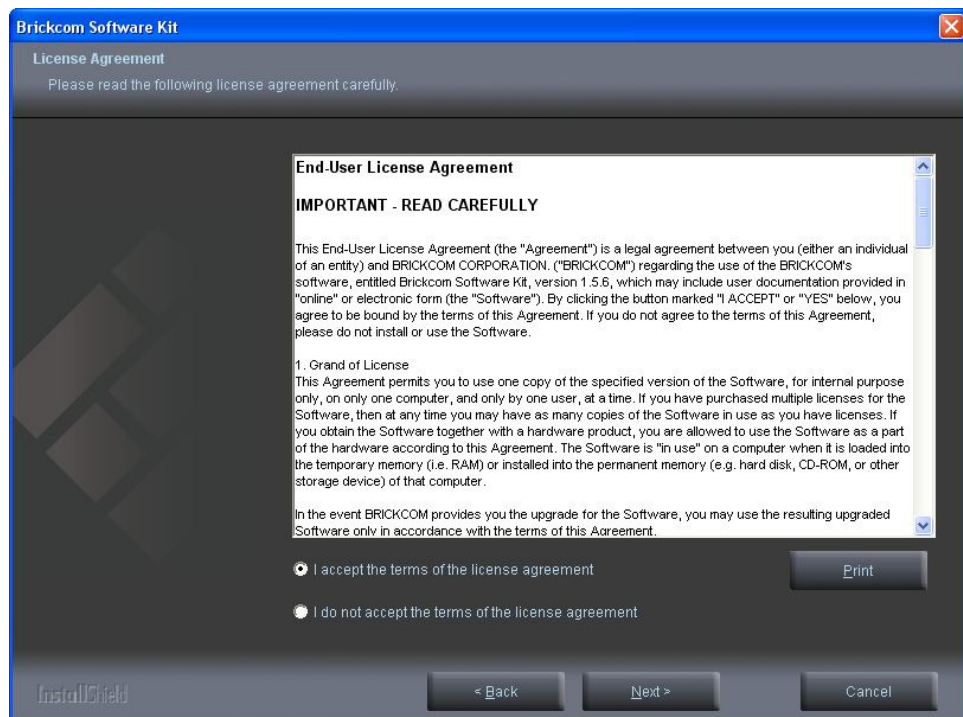

- D. Select either “Complete” setup or “Custom” setup to install the system.
- a. If **COMPLETE SETUP** is selected:
- i. **All program features** will be installed into the default directory. Check the option “**Complete**” and then click <Next>.

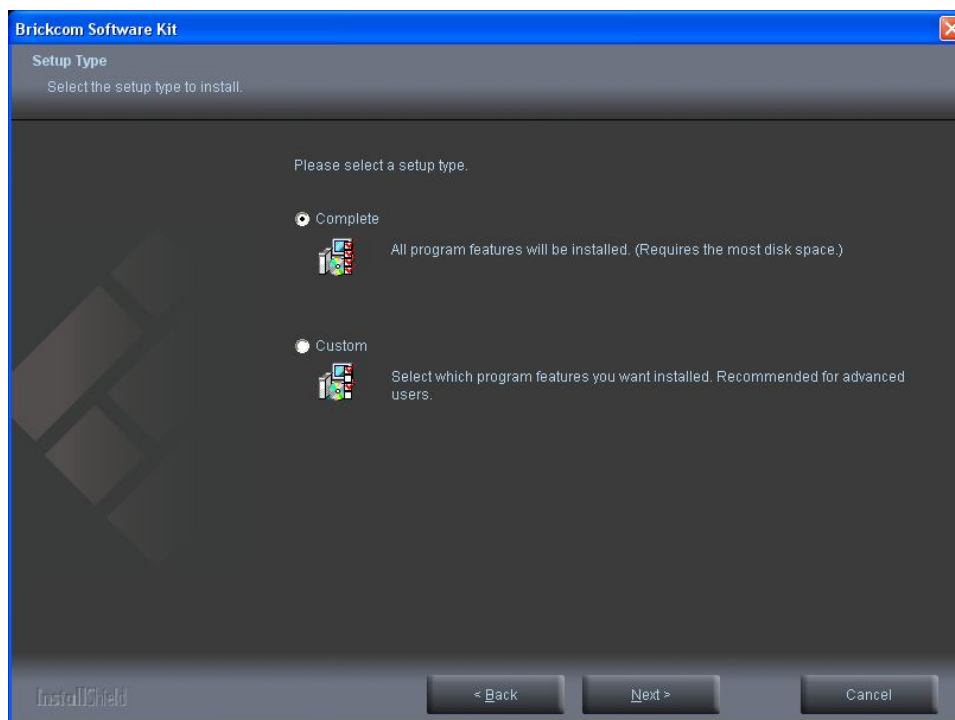

- ii. Click <Change> to change the appointed folder where installation and program files will be stored. Click <Next> to continue.

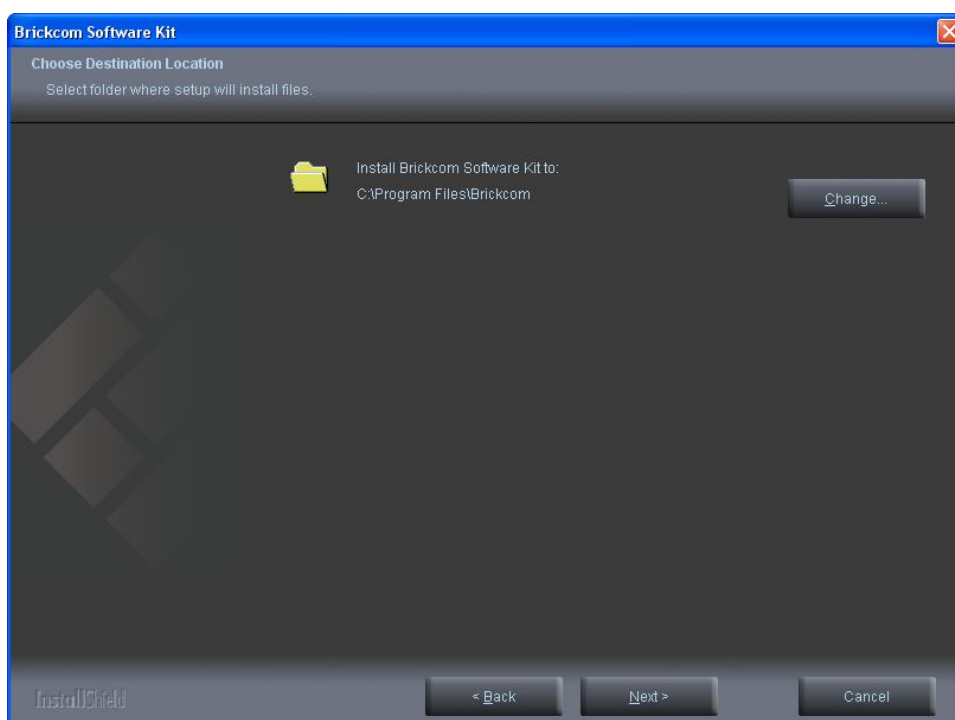

iii. Select to create shortcuts. Click <Next> to continue.

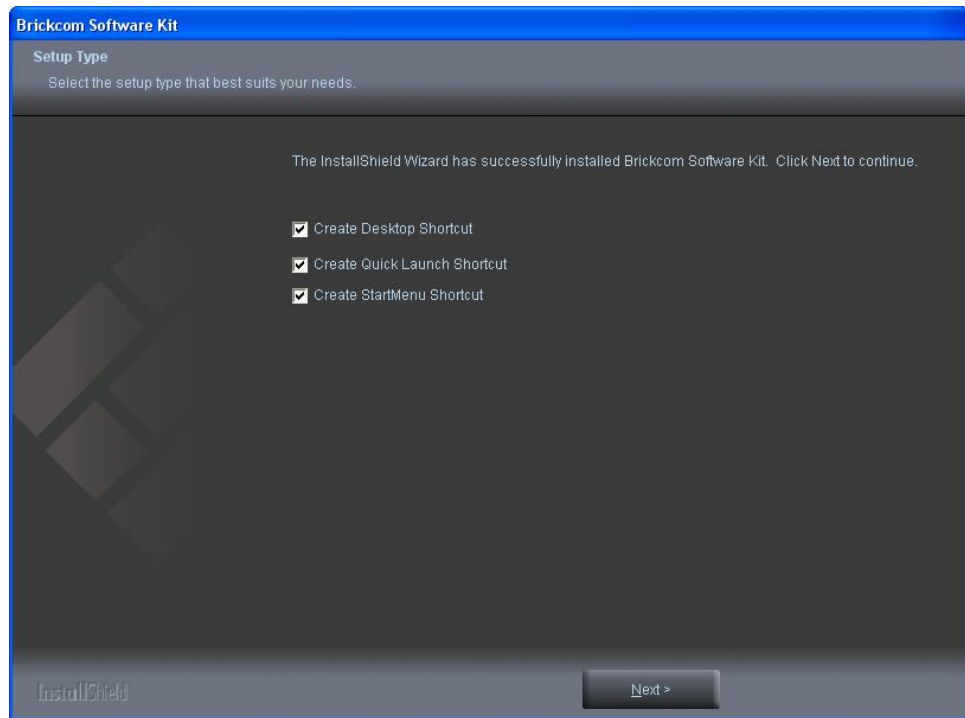

iv. The installation information will be displayed. Click <Next> to continue.

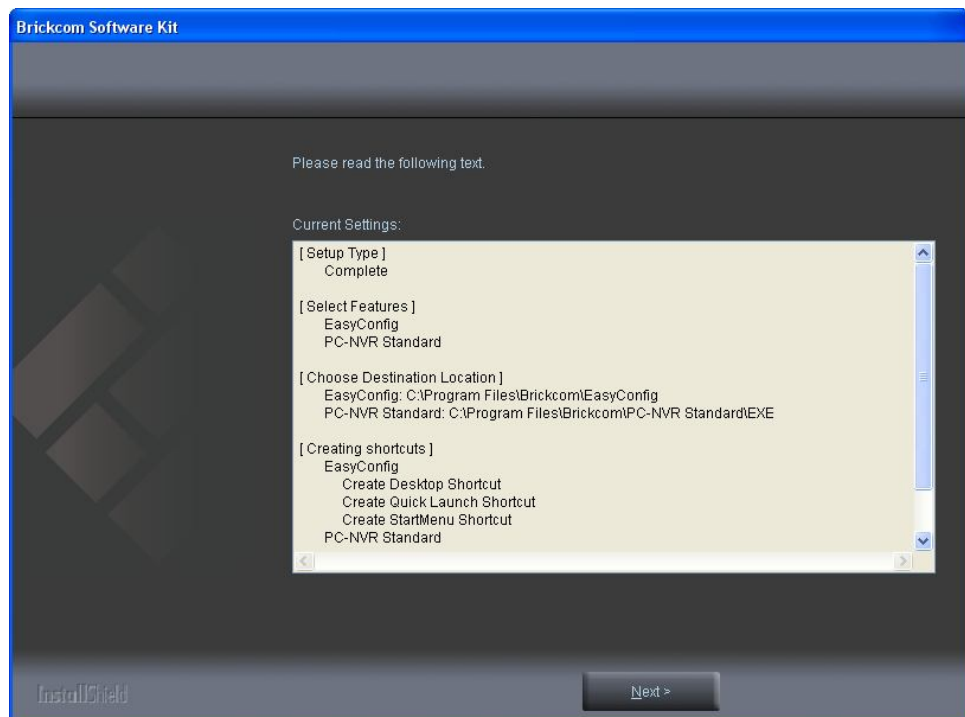

- v. To launch EasyConfig or PC-NVR Standard, select the application and click <Finish>. When launching the PC-NVR program, please refer to the PC-NVR user manual.

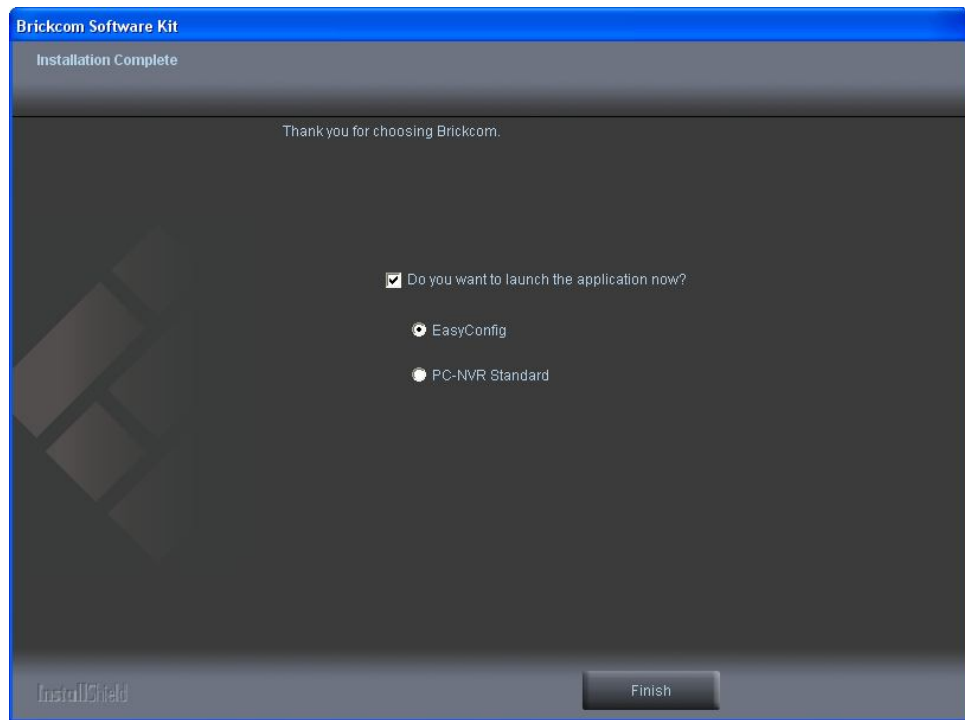

b. If CUSTOM SETUP is selected:

- i. This option is recommended for advanced users. It can be used to install the system to a preferred directory or to select specific program feature(s).
- ii. Check the option "Custom", and then click <Next>.

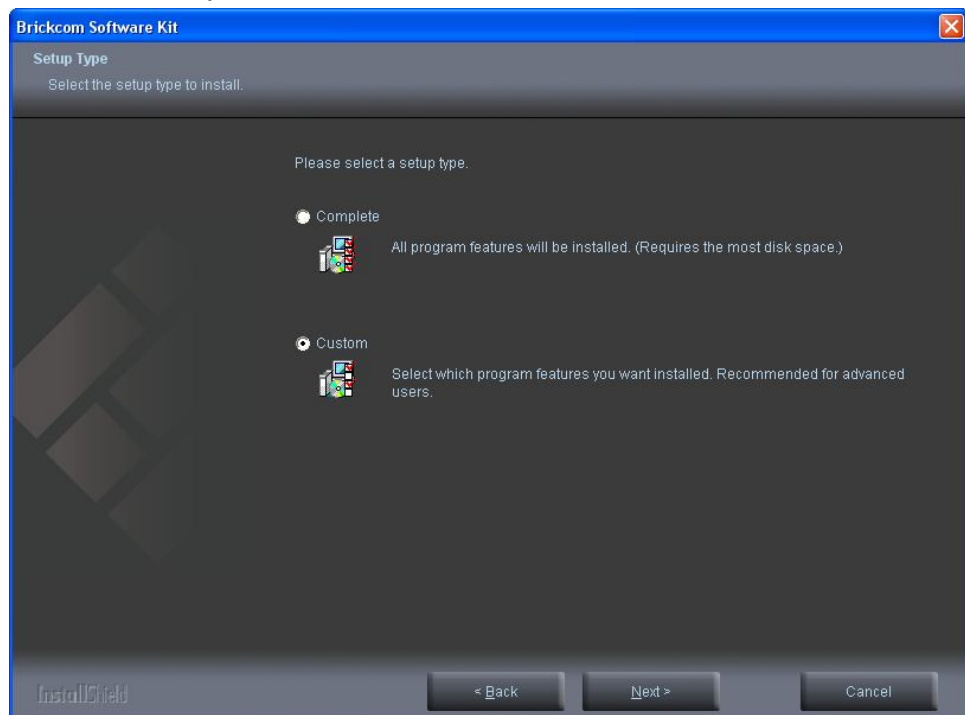

iii. Select the features to install. Click <Next> to continue.

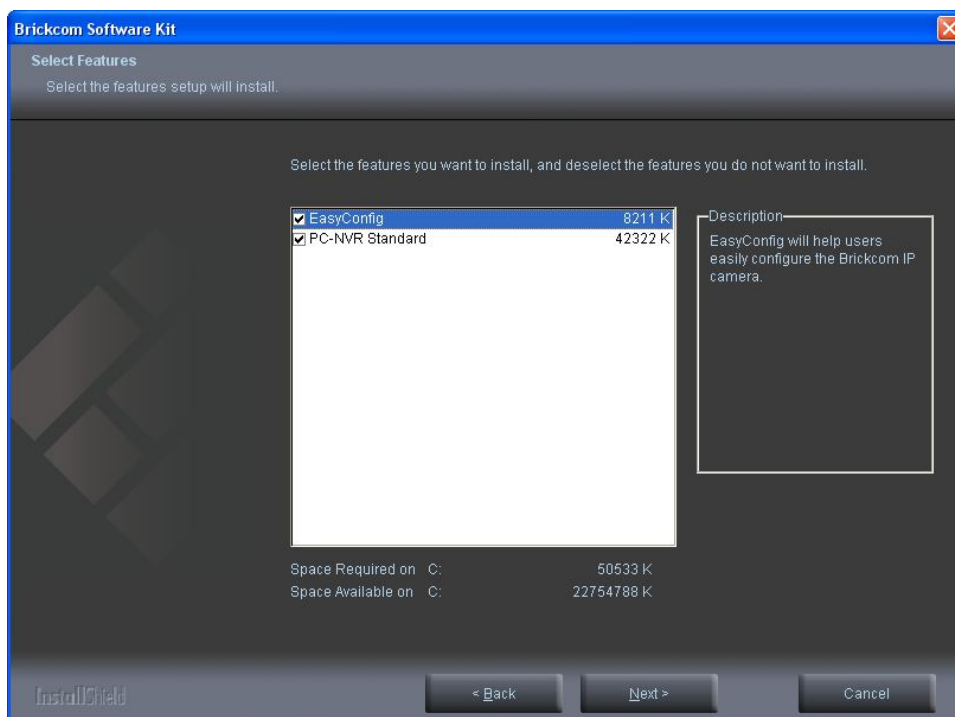

iv. Click <Change> to change the appointed folder where installation and program files will be stored. Click <Next> to continue.

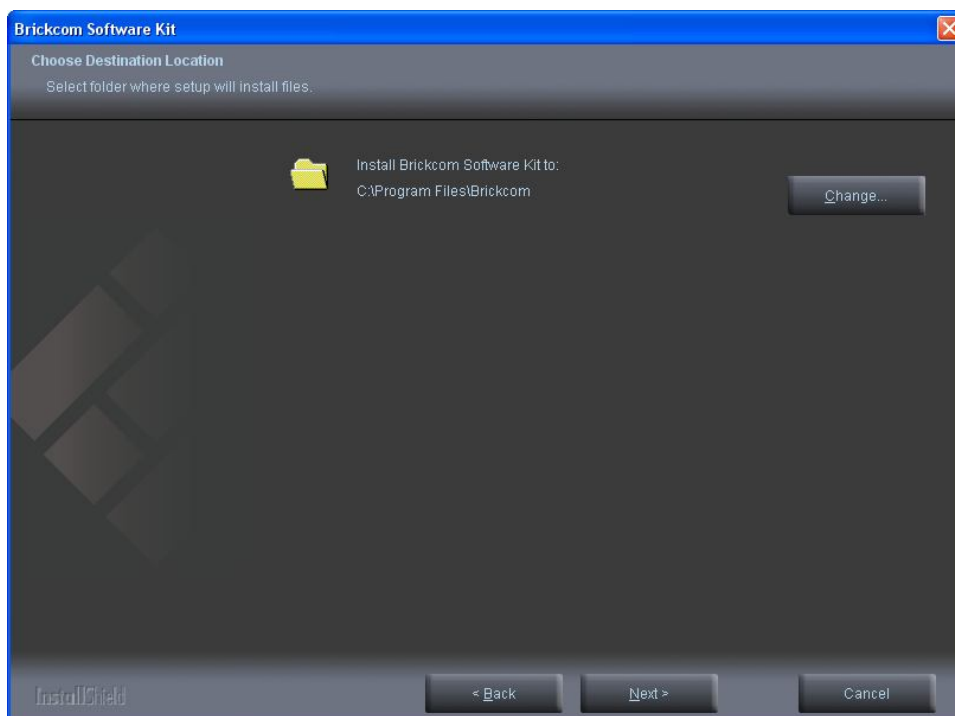

- v. Select programs to create shortcuts. Click <Next> to continue.

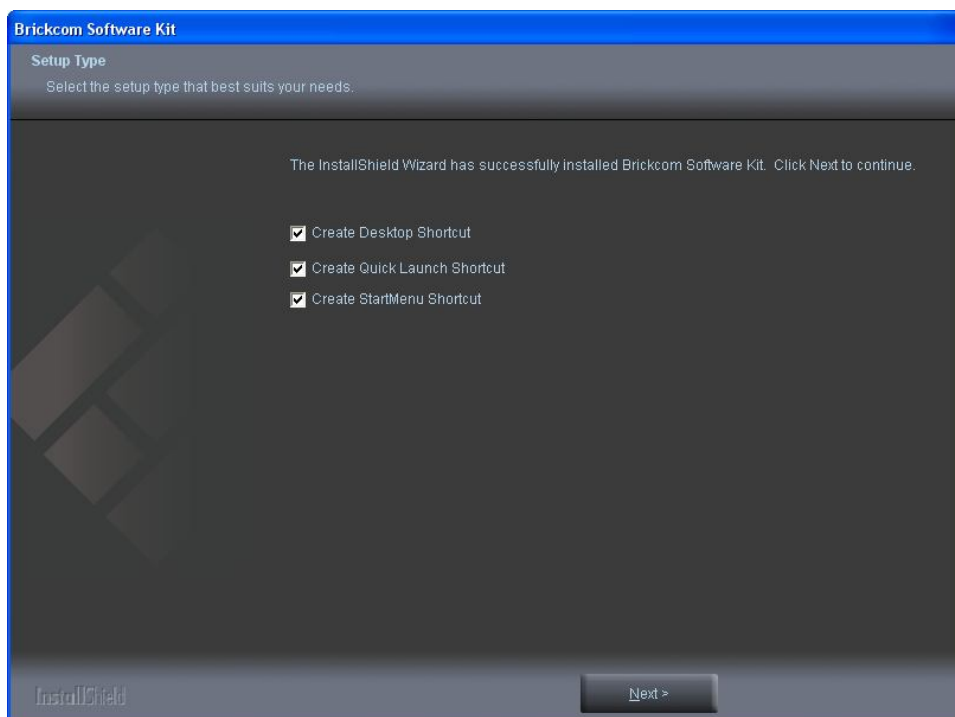

- vi. The installation information will be displayed. Click <Next> to continue.

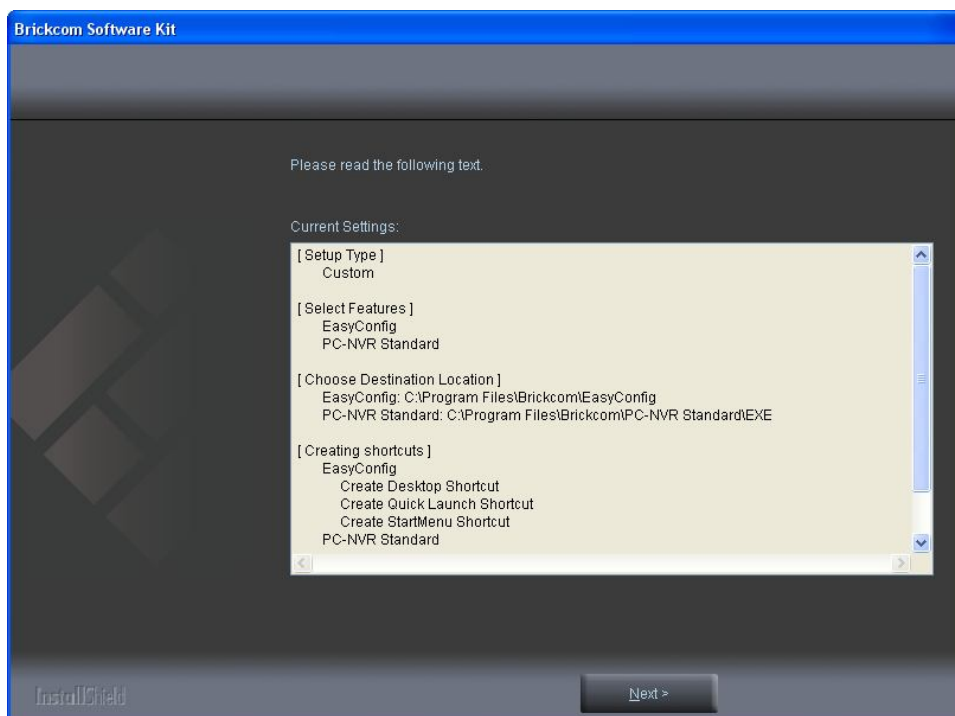

- E. To launch EasyConfig or PC-NVR Standard, select the application and click <Finish>. When launching the PC-NVR program, please refer to the PC-NVR user manual.

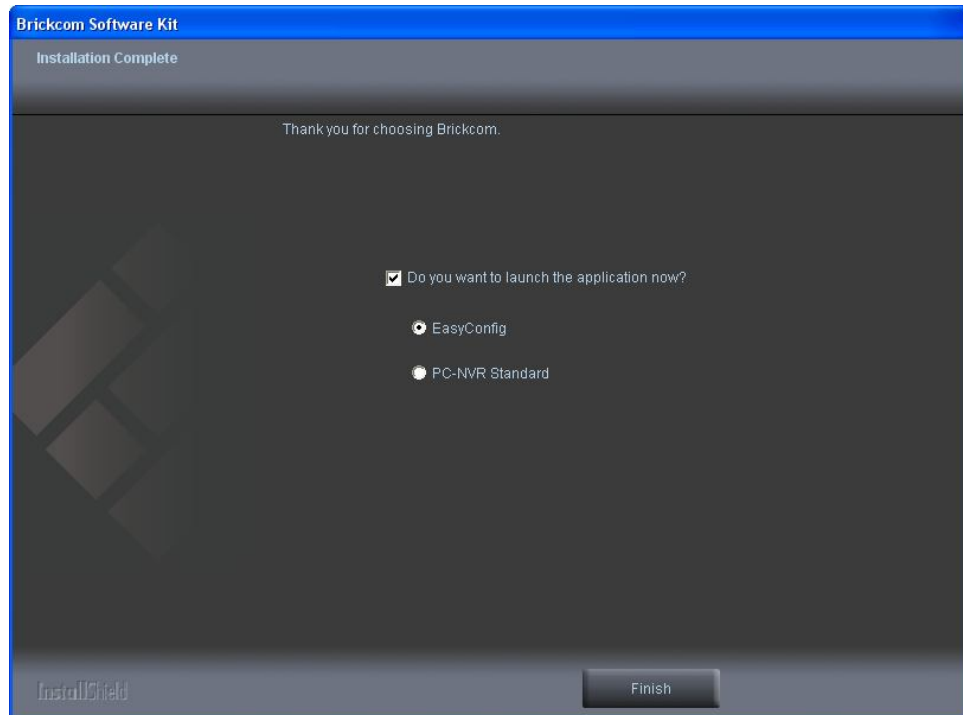

4.4.1 EasyConfig

To launch EasyConfig, select EasyConfig from the start menu. If Complete Setup type was used in the software installation, an EasyConfig icon was installed on the desktop. Double click to open the icon.

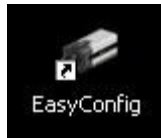

If Custom Setup type was used in the software installation and an EasyConfig icon was not installed on the desktop, the program will be installed under C:\Program Files\Brickcom\EasyConfig unless the program was saved to a preferred directory.

A. Click <Start> to continue. The program will automatically search for the camera in the intranet.



NOTE - Check “Skip the hardware installation guide” to skip checking the hardware connection. To check the hardware installation settings, do not check the option box.



Brickcom

Connection

1 Plug one end of the supplied network cable into your network switch or router.

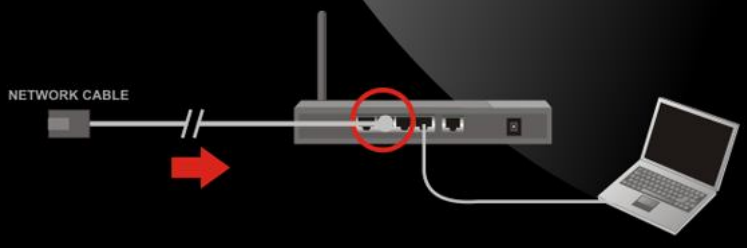

NETWORK CABLE

Diagram illustrating the first step of connection: a network cable is being plugged into the Ethernet port of a network switch or router. The router is connected to a laptop. A red circle highlights the Ethernet port on the router, and a red arrow points to the network cable being inserted.

Brickcom

2 Plug the other end of the supplied network cable into the camera's Ethernet port.

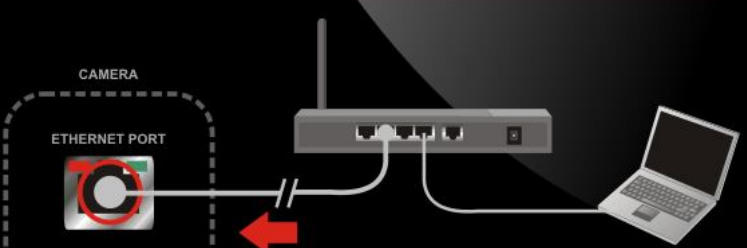

CAMERA

ETHERNET PORT

Diagram illustrating the second step of connection: the other end of the network cable is being plugged into the Ethernet port of the camera. The camera is connected to a network switch or router, which is connected to a laptop. A red circle highlights the Ethernet port on the camera, and a red arrow points to the network cable being inserted.

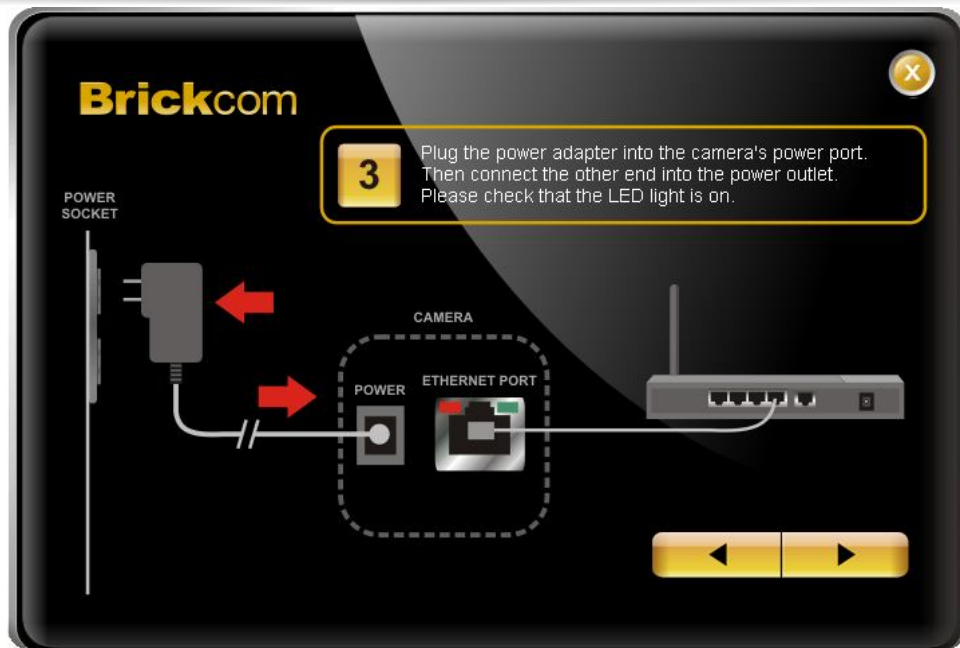

- B. Select either "Simple Mode" or "Professional Mode" to obtain the camera's IP settings. If "Simple Mode" is selected, EasyConfig will set up the connection automatically. If "Professional Mode" is selected, the user will need to configure the IP settings manually.



- C. There may be many cameras in the local network. Differentiate the cameras using their UPnP name. Double click on the camera from the survey list to connect.

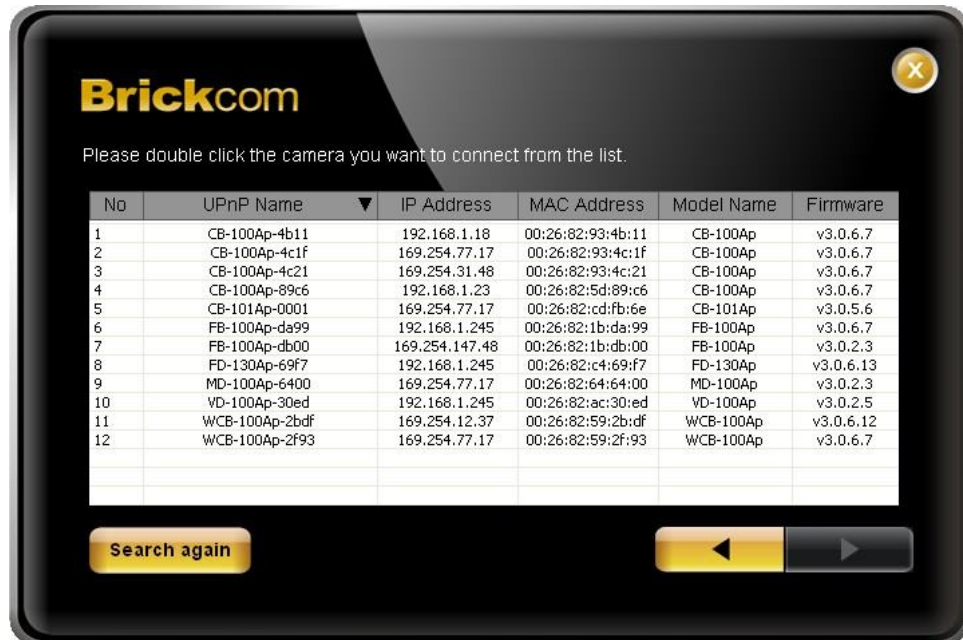

- D. For configuring the IP address settings, select either <Settings remain the same>, <Automatically obtain an IP Address (DHCP)> or <Set IP Address configuration manually>. The DHCP setting is recommended.



If <Set IP Address configuration manually> is selected, the following pages will be displayed.

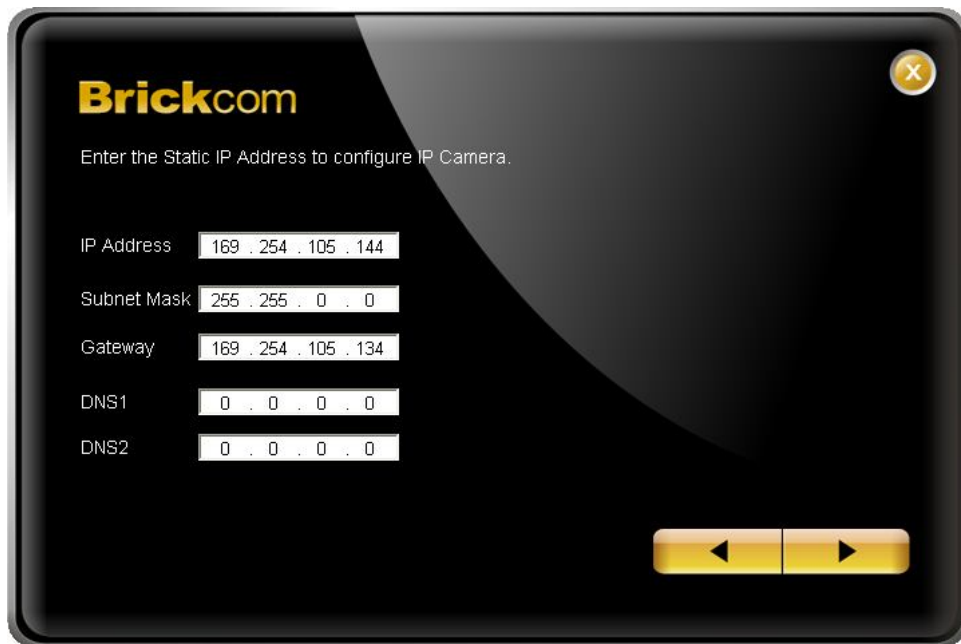

- E. If the camera supports the EasyLink™ function, the following page will be displayed. Otherwise, this page will not be shown. *If desired, click <Skip> to skip this setting.

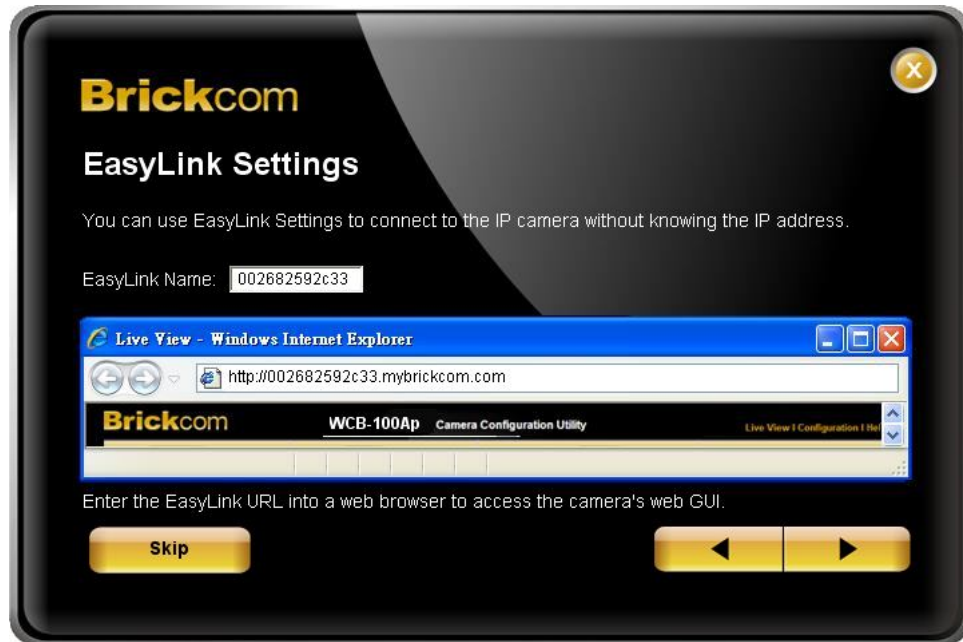

EasyLink™ is a unique Brickcom function which allows users to assign a unique EasyLink name to their network camera's IP address. There is no need to configure the router to open up ports or remember hard-to-memorize IP addresses. Users can log onto [uniqueEasyLinkname].mybrickcom.com to view the camera's web GUI and live view.

- a. Enter a unique EasyLink name whose length must be between 5-32 characters.
- b. When finished, click the arrow button to continue.

- F. When the IP address settings have been configured, the screen will either display a successful or failed connection message. If the connection failed, either try again or quit the installation.
- a. If “DHCP IP address settings” was selected, the failure page will be displayed as below:

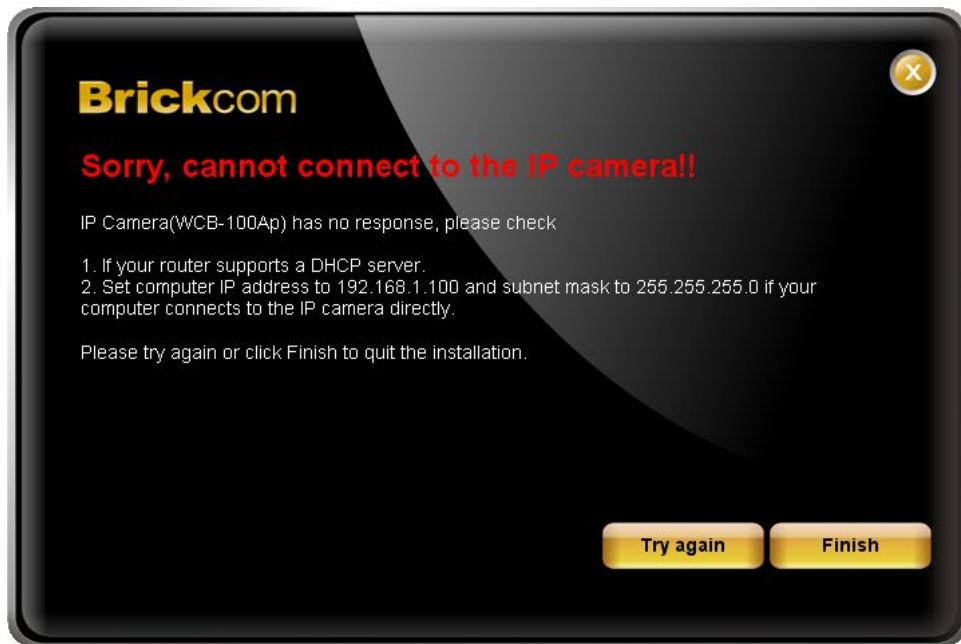

- b. If “Static IP address settings” was selected, the failure page will be displayed as below:

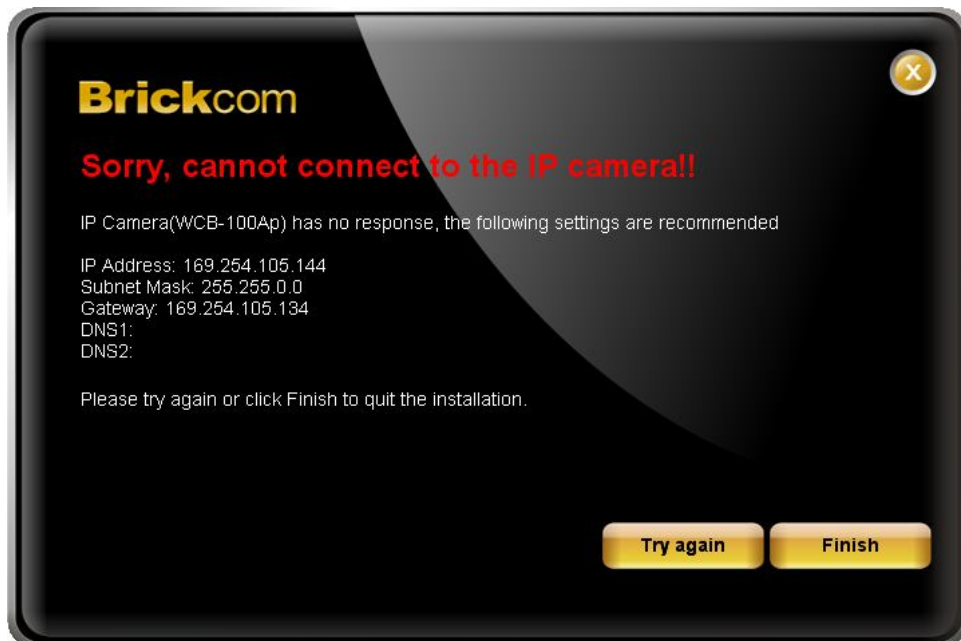

- c. If the connection was successful, the user will see the message: "Congratulations. The installation of the camera is complete."

When this window is displayed, click <PC-NVR> to start the PC-NVR program, <Live View> to view the live video from the connected IP camera, or <X> in the top right corner of the screen to close the installation window. If the user starts the PC-NVR program, please refer to the PC-NVR user manual.



Once installation is complete, the Administrator should proceed to the next section "Accessing the Network Camera" for necessary changes and configurations.